

SIGNETICS
2650
MICROPROCESSOR

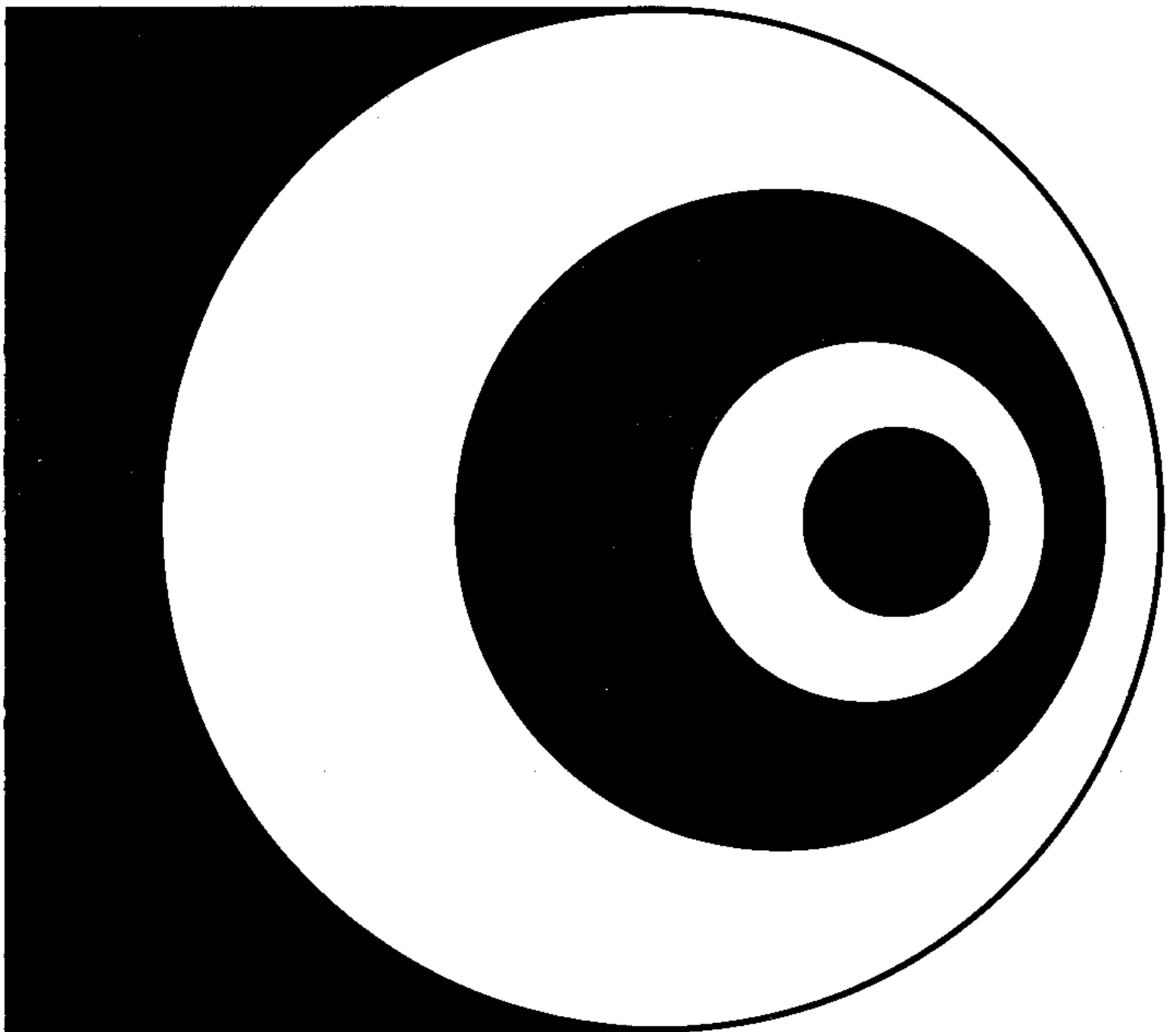

CONTENTS

I INTRODUCTION

INTRODUCING THE 2650 FAMILY	3
FEATURES OF THE 2650 FAMILY	4
Family Approach	4
Microprocessor Features	4
Compatible Products	5
PROCESSOR HARDWARE DESCRIPTION	6
Architecture	6
Interfacing	8
Instruction Set	12
SUPPORT	15
Documentation	15
Software Support	15
Prototyping Hardware	16
System Compatible Families	16

II 2650 HARDWARE

INTRODUCTION	19
General Features	18
Applications	20
INTERNAL ORGANIZATION	21
Internal Registers	21
Program Status Word	22
Memory Organization	27
INTERFACE	29
Signals	29
Signal Timing	34
Electrical Characteristics	37
Interface Signals	39
Pin Configuration	39
FEATURES	41
Input/Output Facilities	41
Interrupt Mechanism	43
Subroutine Linkage	45
Condition Code Usage	45
Start-up Procedure	46
INSTRUCTIONS	47
Addressing Modes	47
Instruction Formats	51
Detailed Processor Instructions	52

III	2650 ASSEMBLER LANGUAGE	
	INTRODUCTION	93
	LANGUAGE ELEMENTS	97
	Characters	97
	Symbols	97
	Constants	97
	Multiple Constant Specifications	99
	Expressions	99
	Special Operators	100
	SYNTAX	101
	Fields	101
	Symbols	102
	Symbolic References	102
	Symbolic Addressing	102
	PROCESSOR INSTRUCTIONS	105
	DIRECTIVES TO THE 2650 ASSEMBLER	106
	THE ASSEMBLY PROCESS	115
	Assembly Listing	118
IV	2650 SIMULATOR	
	INTRODUCTION	123
	SIMULATOR OPERATION	124
	General	124
	Simulated Processor State	124
	Simulated Memory	125
	Simulated Input/Output Instructions	125
	USER COMMANDS	126
	General	126
	Command Formats	127
	Command Descriptions	130
	SIMULATOR DISPLAY (LISTING)	139
V	APPENDIXES	
	APPENDIX A MEMORY INTERFACE EXAMPLE	147
	APPENDIX B I/O INTERFACE EXAMPLE	148
	APPENDIX C INSTRUCTIONS, ADDITIONAL INFORMATION	149
	APPENDIX D INSTRUCTION SUMMARY	151
	APPENDIX E SUMMARY OF 2650 INSTRUCTION MNEMONICS	160
	APPENDIX F NOTES ABOUT THE 2650 PROCESSOR	162
	APPENDIX G ASCII AND EBCDIC CODES	163
	APPENDIX H COMPLETE ASCII CHARACTER SET	164
	APPENDIX I POWERS OF TWO TABLE	165
	APPENDIX J HEXADECIMAL-DECIMAL CONVERSION TABLES	166
	APPENDIX K COMMAND SUMMARY	171
	APPENDIX L ERROR MESSAGES	172
	APPENDIX M SIMULATOR RESTRICTIONS	174
	APPENDIX N SIMULATOR RUN PREPARATION	174

CHAPTER I
INTRODUCTION



INTRODUCING THE 2650 FAMILY

*"5-VOLT SYSTEM REDUCES SYSTEM COSTS"
"2650 PUTS THE INTERFACE ON THE CHIP...NOT ON THE CIRCUIT BOARD"
"POWERFUL INSTRUCTION SET PROVIDES LOWER COST SYSTEMS"*

The greatly increased sophistication and rising production costs of today's logic systems force the system designer to use every available resource in order to economically produce his system. In keeping with this cost reduction goal, Signetics has developed a powerful general purpose integrated microprocessor called the 2650. The first Signetics microprocessor, in conjunction with Signetics MOS and Bipolar memory and interface product lines, offers the system designer a viable and attractive alternative to the hard-wired approach to system design. For many applications, the system designer can use this general purpose microprocessor and standard memory and interface circuits to implement systems with lower cost than the hard-wired logic approach without sacrificing performance.

By using the 2650 and compatible products, the system designer can obtain two other major benefits of microcomputer systems. These benefits are greatly enhanced system flexibility and minimized design or modification cycles compared with the hard-wired logic approach.

The requirements of the majority of applications for integrated microprocessors (logic replacement and control functions) have defined a general set of processor parameters based on system and device economies, ease of use, and speed requirements.

These characteristics include:

- Single chip
- Fixed instruction set
- Eight bit parallel structure
- TTL compatibility

In addition to these characteristics, the design of the 2650 has been optimized around three generalized objectives:

- Lowest system cost
- Ease of use
- Capable of a wide range of applications

The optimum technology choice for implementing these features is the low threshold ion-implanted N-Channel silicon gate process. This process has matured in the past few years, providing a combination of high density, low threshold voltage, moderate speed and good manufacturing yields. Using this technology, a total of 576 bits of ROM, approximately 250 bits of register and about 900 logic gates are used to implement the processor function on the 2650 chip.

The instruction set consists of 75 instructions, of which about 40% consists of arithmetic instructions. This class contains the Boolean, arithmetic, and compare operations, each of which may be executed using any one of eight addressing modes. Another 30% of the instruction set consists of branch instructions which incorporate six addressing modes. The remaining 30% of the instruction set includes, among others, I/O instructions, instructions for performing operations on the two status registers, a decimal adjust instruction and the HALT instruction.

Utilizing multiple addressing modes greatly increases coding efficiency, allowing functions to be performed using fewer instructions than less powerful machines. The resulting reduction in routine execution time and memory capacity requirements directly translates into improved system performance and reduced memory cost. In this way the powerful instruction set and addressing modes of the 2650 allow a significant reduction in the memory required to perform a given function, resulting in sizeable system cost savings without sacrificing performance.

FEATURES OF THE 2650 FAMILY

2650 FAMILY APPROACH

- * Low System Cost
 - Low cost N-Channel products
 - Intrinsic advantages of single 5V supply
 - Uses standard low cost memories
 - Low cost interfacing
- * Ease of Use
 - Easy interfacing
 - Conventional instruction set
 - Ease of programming
- * Wide Range of Applications
 - General purpose capability
 - Powerful architecture
 - Powerful instruction set
 - Flexible
 - Expanding family of devices

FEATURES OF THE MICROPROCESSOR

Basic 2650 Processor Characteristics

- * Single chip 8-bit processor
- * Signetics low threshold double ion-implanted silicon gate N-Channel technology
- * Single +5V power supply
- * Low power consumption: 525 mW maximum
- * Single phase TTL-compatible clock
- * Static operation: no minimum clock frequency
- * Clock frequency: 1.25MHz maximum
- * Cycle time: 2.4 μ s minimum
- * Standard 40 pin DIP

2650 Interfaces

- * TTL compatible inputs, outputs — no external resistors required
- * Tri-state bus outputs for multiprocessor and direct memory access systems
- * Asynchronous (handshaking) memory and I/O interface
- * Accepts wide range of memory timing
- * Interfaces directly with industry standard memories
- * Powerful control interface
- * Single-bit direct serial I/O path
- * Parallel 8-bit I/O capability

2650 Processor Architecture

- * 8-bit bidirectional tri-state data bus
- * Separate tri-state address bus
- * 32,768-byte addressing range
- * Internal 8-bit parallel structure
- * Seven 8-bit addressable general purpose registers
- * Eight-level on-chip subroutine return address stack
- * Program status word for flexibility and enhanced processing power
- * Single-level hardware vectored interrupt capability
- * Interrupt service routines may be located anywhere in addressable memory
- * Separate adder for fast address calculation

2650 Instruction Set

- * General purpose instruction set with substantial capabilities in arithmetic, character manipulation and control and I/O processing
- * Fixed instruction set
- * 75 instructions
- * Up to eight addressing modes
- * True indexing with optional auto increment/decrement
- * One, two or three byte instructions
- * One- and two-byte I/O instructions
- * Selective test of individual bits
- * Powerful instruction set and addressing modes minimize memory requirements

FEATURES OF COMPATIBLE PRODUCTS

2602, 2606, 1K RAMs

- * Completely static operation
- * N-Channel silicon gate technology
- * 1024 X 1 organization (2602)
256 X 4 organization (2606)
- * Single +5V power supply
- * 200mW typical power dissipation
- * Maximum access time:
1 μ s : 2602
750ns : 2606
650ns : 2602-2
500ns : 2602-1, 2606-1
- * TTL-compatible
- * Tri-state outputs
- * Data I/O bus (2606 only)
- * Standard 16 pin DIP

2608 8K ROM

- * Completely static operation
- * N-Channel silicon gate technology
- * 1024 X 8 organization
- * Single +5V power supply
- * 400mW maximum power dissipation
- * 650ns maximum access time
- * TTL compatible
- * Tri-state outputs
- * Standard 24 pin DIP

8T26 Quad Transceiver

- * Schottky TTL technology
- * Four pairs of bus drivers/receivers
- * Separate drive and receive enable lines
- * Tri-state outputs
- * Low current pnp inputs
- * High fan out — driver sinks 40mA
- * 20ns maximum propagation delay
- * Standard 16 pin DIP

8T31 8-bit Bidirectional Port

- * Schottky TTL technology
- * Two independent bidirectional busses
- * Eight bit latch register
- * Independent read, write controls for each bus
- * Bus A overrides if a write conflict occurs
- * Register can be addressed as a memory location via Bus B Master Enable
- * 30ns maximum propagation delay
- * Low input current: 500 μ A
- * High fan out — sinks 20mA
- * Standard 24 pin DIP

8T95/6/7/8 Hex Buffers/Inverters

- * Schottky TTL technology
- * Six buffers or inverters per package
- * Non-inverting (8T95, 8T97) or
Inverting (8T96, 8T98)
- * Buffered control lines
- * Tri-state outputs
- * Low current pnp inputs
- * Standard 16 pin DIP

82S115/123/129 PROMs

- * Schottky TTL technology
 - * Single +5V power supply
 - * 32 X 8 organization (82S123)
 - * 256 X 4 organization (82S129)
 - * 512 X 8 organization (82S115)
 - * Field programmable (Nichrome)
 - * On-chip storage latches (82S115 only)
 - * Low current pnp inputs
 - * Tri-state outputs
 - * 35ns typical access time
 - * Standard 24 pin DIP (82S115)
 - * Standard 16 pin DIP (82S123, 82S129)
- (See Appendix for additional products and data sheets.)

PROCESSOR HARDWARE DESCRIPTION

ARCHITECTURE

GENERAL DESCRIPTION

A block diagram of the processor is shown in Figure 1. The first, second, and third bytes of instructions are read into the processor on the data bus and loaded into the Instruction Register, Holding Register, and Data Bus Register, respectively. The instructions are decoded through a combination of ROM and random logic.

The ALU performs arithmetic, Boolean, and combinatorial shifting functions. It operates on eight bits in parallel and utilizes carry-look-ahead logic. A second adder is used to increment the instruction address register and to calculate operand addresses for the indexed and relative addressing modes. This separate address adder allows complex addressing modes to be implemented with no increase in instruction execution time.

The General Purpose Register Stack and the Subroutine Return Address Stack are implemented with static RAM cells. The Register Stack consists of seven 8-bit registers. The Subroutine Stack can contain eight 15-bit addresses, thereby allowing eight levels of subroutine nesting. Placing the Subroutine Stack on the chip allows efficient ROM-only systems to be implemented in some applications. Separate 15-bit Instruction Address and Operand Address Registers are provided. The 2650 is an 8-bit binary processor with BCD capability. See Figure 2 for a diagram of the 2650 registers as seen by the programmer.

PROGRAM STATUS WORD

The Program Status Word (PSW) is a major feature of the 2650 with greatly increases its flexibility and processing power. The PSW is a special purpose register within the processor that contains status and control bits.

It is divided into two bytes called the Program Status Upper (PSU) and Program Status Lower (PSL). The PSW bits may be tested, loaded, stored, preset, or cleared using the instructions which affect the PSW. The bits are utilized as follows:

PSU0, 1,2	— SP	— Pointer for the Return Address Stack.
PSU5	— II	— Used to Inhibit recognition of additional Interrupts.
PSU6	— F	— Flag is a latch directly driving the flag output.
PSU7	— S	— Sense equals the state of the sense input.
PSL0	— C	— Carry stores any carry from the high-order bit of the ALU.
PSL1	— COM	— Compare determines if a logical or arithmetic comparison is to be made.
PSL2	— OVF	— Overflow is set if a two's complement overflow occurs.
PSL3	— WC	— With Carry determines is the carry is used in arithmetic and rotate instructions.
PSL4	— RS	— Register Select identifies which bank of 3 GP registers is being used.
PSL5	— IDC	— Inter Digit Carry stores the bit-3-to-bit-4 carry in arithmetic operations.
PSL6, 7	— CC	— Condition Code is affected by compare, test and arithmetic instructions.

INTERRUPT HANDLING CAPABILITY

The 2650 has a single level hardware vectored interrupt capability. When an interrupt occurs, the 2650 finishes the current instruction and sets the

Interrupt inhibit bit in the PSW. The processor then executes a Branch to Subroutine Relative to location Zero (ZBSR) instruction and sends out Interrupt Acknowledge and Operation Request signals. On receipt of the INTACK signal the interrupting device inputs an 8-bit address, the interrupt vector, on the data bus. The relative and relative indirect addressing modes combined with this 8-bit address allow interrupt service routines to begin at any addressable memory location.

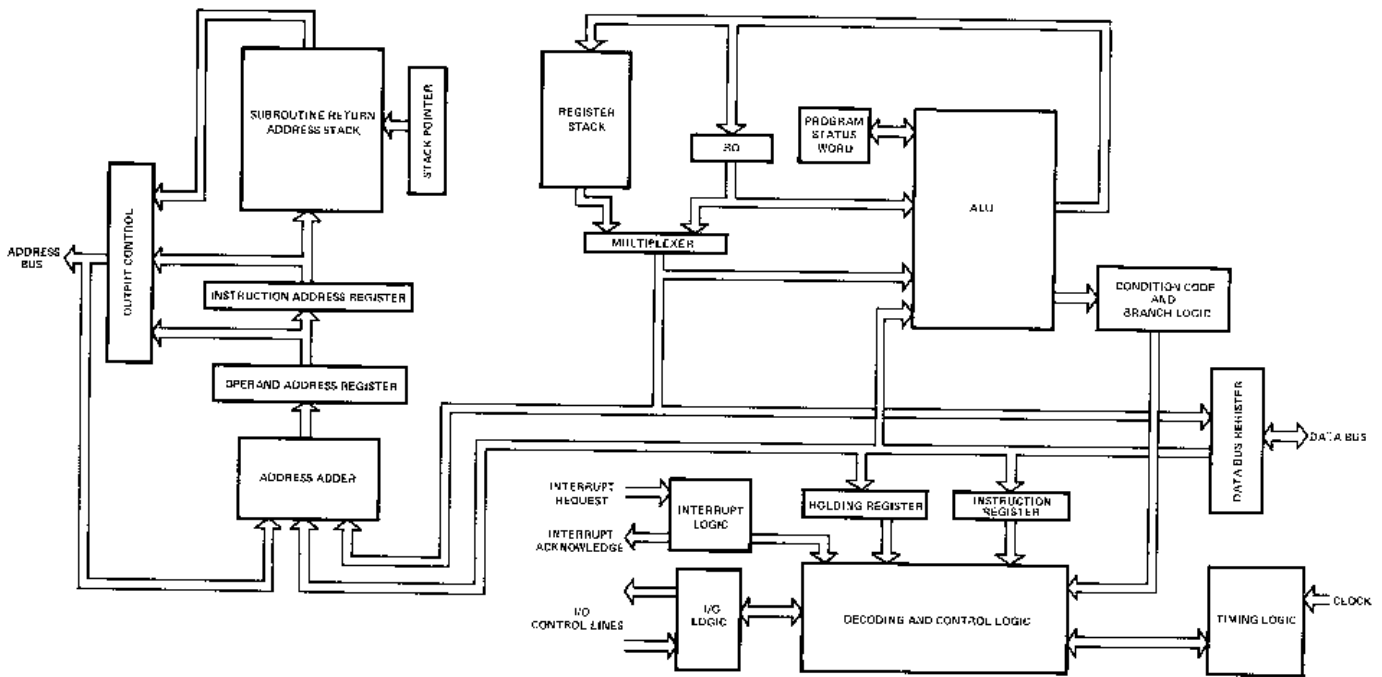
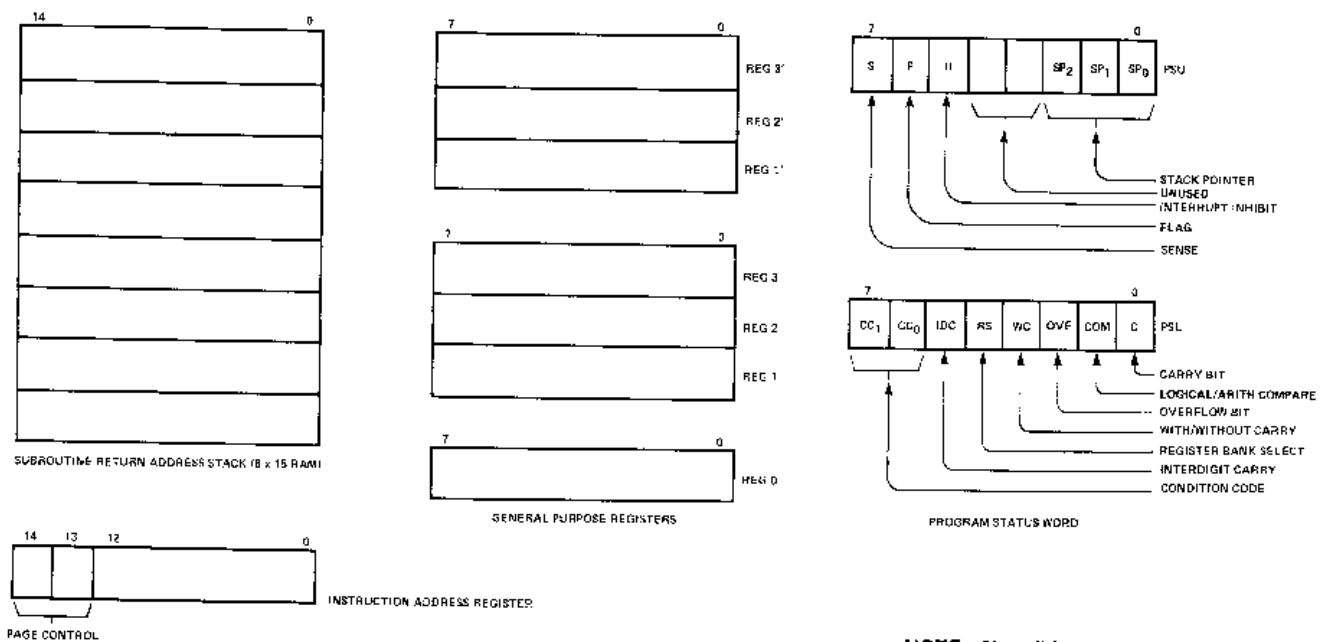

Figure 1. BLOCK DIAGRAM



NOTE: Not all internal registers are shown.

Figure 2. MAJOR 2650 REGISTERS

INTERFACING

INTRODUCTION TO INTERFACING WITH THE 2650

Five key concepts have been incorporated in the 2650 to make interfacing easy and inexpensive. The extent to which these concepts have been incorporated in the Signetics 2650 provides unique benefits of system density and low cost to the system designer.

1. SINGLE 5V POWER SUPPLY

Low threshold double ion-implanted Silicon Gate N-Channel MOS technology is used to allow operation from one +5V power supply with resultant cost savings and improved reliability. This reduces power consumption significantly compared with the multi-power supply approach.

2. INTERFACE CIRCUIT COMPATIBILITY

The 2650 inputs and outputs are specified to be compatible with widely available, standard, low cost logic families such as TTL, CMOS and Low-power STTL. This includes the single phase clock input which saves the cost of high level multiphase clock driver circuitry. Bus outputs are tri-state and capable of driving one 7400 TTL load or four 74LS loads. The 2650 is capable of driving several loads of pnp-buffered STTL inputs. Many MSI, Interface and Memory LSI circuits (for example, in Signetics 82S00 and 8T00 series) have these low current pnp inputs and are recommended for use in 2650 microcomputer systems. See Table 1 for DC characteristics of the 2650.

3. USE OF STANDARD MEMORIES

One of the major 2650 design achievements is to operate efficiently in a system using industry standard memories, for example 1024 X 1 and 256 X 4 N-channel RAMs and 1024 X 8 N-Channel ROMs. These standard memories are widely available and used in volume with corresponding low cost. Non-standard memories, particularly those produced by only one manufacturer will be less available, run in lower volume and often cost 2 to 3 times as much per bit as industry standard products. The 2650 operates successfully with memories of any access time, due to the completely asynchronous interface that is provided for this purpose. Memories which respond in less than 0.8 microseconds allow the processor to operate at maximum speed.

4. NO SPECIAL INTERFACE PRODUCTS

Similarly, another major achievement is to operate efficiently in a system using no special I/O products. This approach avoids the problems of a system requiring high cost specialized components with restricted availability.

TABLE 1. PRELIMINARY 2650 DC ELECTRICAL CHARACTERISTICS

SYMBOL	PARAMETER	TEST CONDITIONS	LIMITS		UNIT
			MIN	MAX	
I _{LI}	Input Load Current	V _{IN} = 0 to 5.25V		10	μA
I _{LOH}	Output Leakage Current	ADREN, DBUSEN = 2.2V, V _{OUT} = 4V		10	μA
I _{LOL}	Output Leakage Current	ADREN, DBUSEN = 2.2V, V _{OUT} = 0.45V		10	μA
I _{CC}	Power Supply Current	V _{CC} = 5.25V, T _A = 0°C		100	mA
V _{IL}	Input Low		-0.6	0.8	V
V _{IH}	Input High		2.2	V _{CC}	V
V _{OL}	Output Low	I _{OL} = 1.6 mA	0.0	0.45	V
V _{OH}	Output High	I _{OH} = -100 μA	2.4	V _{CC} -0.5	V
C _{IN}	Input Capacitance	V _{IN} = 0V		10	pF
C _{OUT}	Output Capacitance	V _{OUT} = 0V		10	pF

Conditions: T_A = 0°C to 70°C, V_{CC} = 5V ±5%

5. POWERFUL MEMORY AND I/O INTERFACE

The following features characterize the memory and I/O interfaces:

- Both memory and input/output may operate in a completely asynchronous fashion. Consequently, devices operating at any speed up to the maximum data transfer rate may be connected without buffering. External latching of data from these interfaces is not required.
- Data paths are driven with tri-state buffers, allowing multiprocessor and Direct Memory Access (DMA) configurations to be designed.
- Eight-bit data paths communicate data in parallel.
- One- and two-byte I/O instructions provide maximum flexibility and efficiency when interfacing with I/O devices.

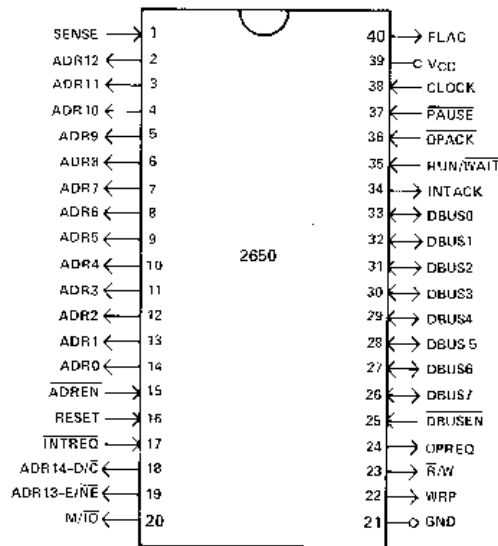

Figure 3. PIN CONFIGURATION

PIN CONFIGURATION AND INTERFACE SIGNAL DEFINITION

Refer to Figure 3 for the 2650 pin configuration. Signals are defined as follows:

- ADR0-ADR12 — The low order 13 bits of address for memory access are on these pins. ADR0-ADR7 are also used in two-byte I/O instructions. These outputs are tri-state buffers controlled by ADREN.
- ADR13-E/NE — This multiplexed output signal delivers the ADR13 address bit when M/IO is in the M phase or discriminates between Extended and Non-Extended I/O instructions when M/IO is in the I/O phase.
- ADR14-D/C — Address 14 or Data/Control is a multiplexed output signal. This pin delivers the ADR14 address bit when M/IO is in the M phase or discriminates between Data and Control I/O instructions when M/IO is in the I/O phase.
- ADREN — Address Bus Enable is an input providing the external control for the ADR0-ADR12 tri-state buffer drivers.
- DBUS0-DBUS7 — This is the 8-bit, bidirectional tri-state bus over which most data is communicated into or out of the processor.
- DBUSEN — Data Bus Enable is an input that controls the tri-state buffer drivers for DBUS0 to DBUS7.
- OPREQ — Operation Request is an output signal that informs external devices that the information on other output pins is valid.

OPACK	— Operation Acknowledge is an input which is used by external devices to end an I/O or memory signaling sequence.
M/IO	— Memory/Input-Output. This output informs external devices whether Memory or Input/Output functions are being performed.
R/W	— This output signal describes an I/O or memory operation as Read or Write, and defines whether the bidirectional DBUS is transmitting or receiving.
WRP	— This Write Pulse is generated during write sequences and may be used to strobe memory or I/O devices.
SENSE	— Is an input, independent of the other I/O signals, that provides a direct input to the processor.
FLAG	— This pin provides a direct output signal that is completely independent of the other I/O signals.
INTREQ	— Interrupt Request. This input is used by external devices to force the processor into the Interrupt sequence.
INTACK	— Interrupt Acknowledge is the signal used by the processor to inform external devices that it has entered an interrupt sequence.
PAUSE	— Pause is used to temporarily stop the processor at the end of the current instruction. It may stop processing for an indefinite length of time and is available to use for DMA (Direct Memory Access).
RUN/WAIT	— Informs external circuits as to the Run/Wait status of the 2650 processor.
RESET	— Is an input used to cause the 2650 to begin processing from a known state.
CLOCK	— This is the only clock input to the processor. It accepts standard TTL levels.
VCC	— +5V power.
GND	— The logic and power supply ground for the processor.

2650 TIMING

The clock input to the 2650 provides the basic timing information that the processor uses for all its internal and external operations. The clock rate determines the instruction execution time, except to the extent that external memories and devices slow the processor down. The maximum clock rate of the standard 2650 is 1.25 Megacycles (one clock period is 800ns minimum). One unique feature of the 2650 is that the clock frequency may be slowed down to DC, allowing complete timing flexibility for interfacing. This feature permits single stepping the clock which can greatly simplify system check-out. It also provides an easy method to halt the processor. Each 2650 cycle is comprised of three clock periods. Direct instructions require either 2, 3, or 4 processor cycles for execution and, therefore, vary from 4.8 to 9.6 μ s in duration.

A timing diagram for a memory read cycle is shown in Figure 4. OPREQ (Operation Request) is the master control signal that coordinates all operations external to the processor. When true, OPREQ indicates that other output signals are valid. During a memory read cycle M/IO is in the M (Memory) state and R/W is in the R (Read) state. The address lines and the control lines become valid before OPREQ rises. The data to be read may be returned anytime after OPREQ becomes valid. An OPACK (Operation Acknowledge) should accompany the read data from the memory. The Data and OPACK signals should remain valid for 50 ns after OPREQ falls.

INPUT/OUTPUT INTERFACE

The 2650 microprocessor has a set of versatile I/O instructions and can perform I/O operations in a variety of ways. One- and two-byte I/O instructions are provided, as well as a special single-bit I/O facility. The I/O modes provided by the 2650 are designated as Data, Control, and Extended I/O.

Data or Control I/O instructions are one byte long. Any general purpose register can be used as the source or destination. A special control line indicates if either a Data or Control instruction is being executed. Extended I/O is a two-byte read or write instruction. Execution of an extended I/O instruction will cause an 8-bit address, taken from the second byte of the instruction, to be placed on the low order eight address lines. The data, which can originate or terminate with any general purpose register, is placed on the data bus. This type of I/O can be used to simultaneously select a device and send data to it.

Memory reference instructions that address data outside of physical memory may also be used for I/O operations. When an instruction is executed, the address may be decoded by the I/O device rather than memory.

MEMORY INTERFACE

The memory interface consists of the address bus, the 8-bit data bus and several signals that operate in an interlocked or handshaking mode.

The Write Pulse signal is designed to be used as a memory strobe signal for any memory type. It has been particularly optimized to be used as the Chip Enable or Read/Write signal for the Signetics 2602 and 2606 RAMs.

INTERFACING - A MINIMAL SYSTEM EXAMPLE

The 2650 has been designed for low cost, easy interfacing, which is dramatically illustrated by a minimal system configuration shown in Figure 5. This system has a Teletype interface, 1024 bytes of ROM, and 256 bytes of RAM, yet requires only seven (7) standard integrated circuit packages. The ROM can contain a bootstrap loader and I/O driver programs for the Teletype. Other programs could reside in ROM or be read into RAM via the Teletype. An alternative to the 2608 N-Channel MOS ROM is the 82S115 Bipolar PROM which offers a 512 X 8 organization. Only one +5-volt power supply is required for this system. The advantages of conceptual simplicity and minimum system costs of the 2650 approach will be obvious to the system designer, particularly when compared to alternative microprocessor products.

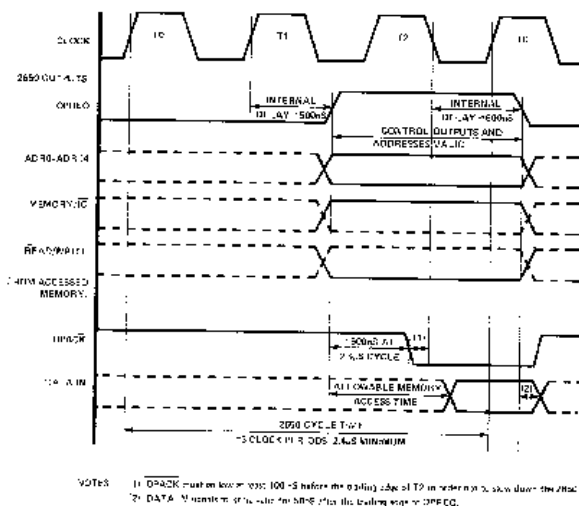

Figure 4. MEMORY READ CYCLE TIMING

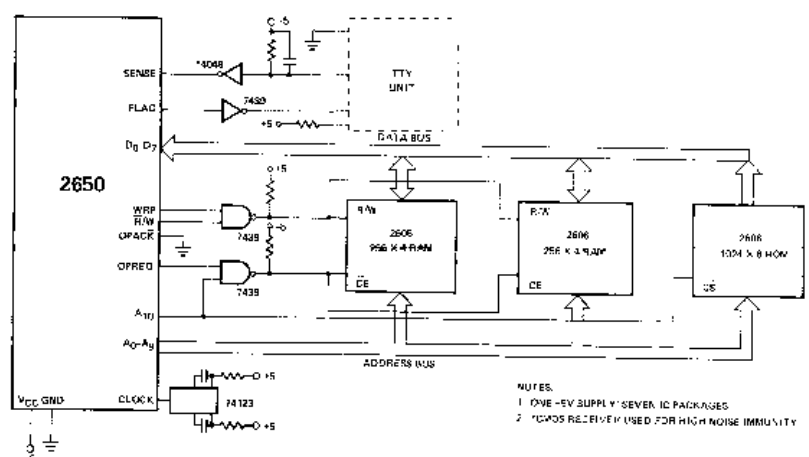

Figure 5. SEVEN PACKAGE MINIMAL SYSTEM

INSTRUCTION SET

It may be seen from examination of the 2650 instruction set that there are many powerful instructions which are all easily understood and are typical of larger computers. There are one-, two-, and three-byte instructions as a result of the multiplicity of addressing modes. See Table 2 for a complete listing and Figure 6 for instruction formats.

Automatic incrementing or decrementing of an index register is available in the arithmetic indexed instructions. All of the branch instructions except indexed branching can be conditional.

Register-to-register instructions are one byte; register-to-storage instructions are two or three bytes long. The two-byte register-to-memory instructions are either immediate or relative addressing types.

TABLE 2. INSTRUCTION SET

	MNEMONIC	OP CODE	FORMAT*	DESCRIPTION OF OPERATION	AFFECTS	CYCLES	
LOAD/STORE	LOD	Z	000 000	1Z	Load Register Zero	CC (Note 1)	2
		I	000 001	2I	Load Immediate	CC (Note 1)	2
		R	000 010	2R	Load Relative	CC (Note 1)	3
		A	000 011	3A	Load Absolute	CC (Note 1)	4
	STR	Z	110 000	1Z	Store Register Zero ($r \neq 0$)	CC (Note 1)	2
		R	110 010	2R	Store Relative	—	3
A		110 011	3A	Store Absolute	—	4	
ARITHMETIC	ADD	Z	100 000	1Z	Add to Register Zero w/w/o Carry	C, CC (Note 1), IDC, OVF	2
		I	100 001	2I	Add Immediate w/w/o Carry	C, CC (Note 1), IDC, OVF	2
		R	100 010	2R	Add Relative w/w/o Carry	C, CC (Note 1), IDC, OVF	3
		A	100 011	3A	Add Absolute w/w/o Carry	C, CC (Note 1), IDC, OVF	4
	SUB	Z	101 000	1Z	Subtract from Register Zero w/w/o Borrow	C, CC (Note 1), IDC, OVF	2
		I	101 001	2I	Subtract Immediate w/w/o Borrow	C, CC (Note 1), IDC, OVF	2
		R	101 010	2R	Subtract Relative w/w/o Borrow	C, CC (Note 1), IDC, OVF	3
		A	101 011	3A	Subtract Absolute w/w/o Borrow	C, CC (Note 1), IDC, OVF	4
	DAR		100 101	1Z	Decimal Adjust Register	CC (Note 2)	3
	LOGICAL	AND	Z	010 000	1Z	AND to Register Zero ($r \neq 0$)	CC (Note 1)
I			010 001	2I	AND Immediate	CC (Note 1)	2
R			010 010	2R	AND Relative	CC (Note 1)	3
A			010 011	3A	AND Absolute	CC (Note 1)	4
IOR		Z	011 000	1Z	Inclusive OR to Register Zero	CC (Note 1)	2
		I	011 001	2I	Inclusive OR Immediate	CC (Note 1)	2
		R	011 010	2R	Inclusive OR Relative	CC (Note 1)	3
		A	011 011	3A	Inclusive OR Absolute	CC (Note 1)	4
EOR		Z	001 000	1Z	Exclusive OR to Register Zero	CC (Note 1)	2
		I	001 001	2I	Exclusive OR Immediate	CC (Note 1)	2
		R	001 010	2R	Exclusive OR Relative	CC (Note 1)	3
		A	001 011	3A	Exclusive OR Absolute	CC (Note 1)	4
ROTATE COMPARE	COM	Z	111 000	1Z	Compare to Register Zero Arithmetic/Logical	CC (Note 3)	2
		I	111 001	2I	Compare Immediate Arithmetic/Logical	CC (Note 4)	2
		R	111 010	2R	Compare Relative Arithmetic/Logical	CC (Note 4)	3
		A	111 011	3A	Compare Absolute Arithmetic/Logical	CC (Note 4)	4
ROTATE COMPARE	RRR	010 100	1Z	Rotate Register Right w/w/o Carry	C, CC, IDC, OVF	2	
	RRL	110 100	1Z	Rotate Register Left w/w/o Carry	C, CC, IDC, OVF	2	
BRANCH	BCT	R	000 110	2R	Branch On Condition True Relative	—	3
		A	000 111	3B	Branch On Condition True Absolute	—	3
	BCF	R	100 110	2R	Branch On Condition False Relative	—	3
		A	100 111	3B	Branch On Condition False Absolute	—	3
	BRN	R	010 110	2R	Branch On Register Non-Zero Relative	—	3
		A	010 111	3B	Branch On Register Non-Zero Absolute	—	3
	BIR	R	110 110	2R	Branch On Incrementing Register Relative	—	3
		A	110 111	3B	Branch On Incrementing Register Absolute	—	3
	BDR	R	111 110	2R	Branch On Decrementing Register Relative	—	3
		A	111 111	3B	Branch On Decrementing Register Absolute	—	3
ZBRR		100 110 11	2ER	Zero Branch Relative, Unconditional	—	3	
BXA		100 111 11	3EB	Branch Indexed Absolute, Unconditional (Note 5)	—	3	

TABLE 2. INSTRUCTION SET (CONTINUED)

	MNEMONIC	OP CODE	FORMAT*	DESCRIPTION OF OPERATION	AFFECTS	CYCLES
SUBROUTINE BRANCH/RETURN	BST	R 001 110	2R	Branch To Subroutine On Condition True, Relative	SP	3
		A 001 111	3B	Branch To Subroutine On Condition True, Absolute	SP	3
	BSF	R 101 110	2R	Branch To Subroutine On Condition False, Relative	SP	3
		A 101 111	3B	Branch To Subroutine On Condition False, Absolute	SP	3
	BSN	R 011 110	2R	Branch To Subroutine On Non-Zero Register, Relative	SP	3
		A 011 111	3B	Branch To Subroutine On Non-Zero Register, Absolute	SP	3
	ZBSR	101 110 11	2ER	Zero Branch To Subroutine Relative, Unconditional	SP	3
	BSXA	101 111 11	3EB	Branch To Subroutine, Indexed, Absolute Unconditional (Note 5)	SP	3
RET	C 000 101	1Z	Return From Subroutine, Conditional	SP	3	
	E 001 101	1Z	Return From Subroutine and Enable Interrupt, Conditional	SP, II	3	
INPUT/OUTPUT	WRTD	111 100	1Z	Write Data	-	2
	REDD	011 100	1Z	Read Data	CC (Note 1)	2
	WRTC	101 100	1Z	Write Control	-	2
	REDC	001 100	1Z	Read Control	CC (Note 1)	2
	WRTE	110 101	2I	Write Extended	-	3
	REDE	010 101	2I	Read Extended	CC (Note 1)	3
MISC.	HALT	010 000 00	1E	Halt, Enter Wait State	-	2
	NOP	110 000 00	1E	No Operation	-	2
	TMI	111 101	2I	Test Under Mask Immediate	CC (Note 6)	3
PROGRAM STATUS	LPS	U 100 100 10	1E	Load Program Status, Upper	F, II, SP	2
		L 100 100 11	1E	Load Program Status, Lower	CC, IDC, RS, WC, OVF, COM, C	2
	SPS	U 000 100 10	1E	Store Program Status, Upper	CC (Note 1)	2
		L 000 100 11	1E	Store Program Status, Lower	CC (Note 1)	2
	CPS	U 011 101 00	2EI	Clear Program Status, Upper, Masked	F, II, SP	3
		L 011 101 01	2EI	Clear Program Status, Lower, Masked	CC, IDC, RS, WC, OVF, COM, C	3
	PPS	U 011 101 10	2EI	Preset Program Status, Upper, Masked	F, II, SP	3
		L 011 101 11	2EI	Preset Program Status, Lower, Masked	CC, IDC, RS, WC, OVF, COM, C	3
TPS	U 101 101 00	2EI	Test Program Status, Upper, Masked	CC (Note 6)	3	
	L 101 101 01	2EI	Test Program Status, Lower, Masked	CC (Note 6)	3	

*FORMAT CODE: The number indicates the number of bytes. The letter(s) indicate the format type(s). See Fig. 6.

NOTES:

1. Condition code (CC1, CC0): 01 if positive, 00 if zero, 10 if negative.
2. Condition code is set to a meaningless value.
3. Condition code (CC1, CC0): 01 if $R0 > r$, 00 if $R0 = r$, 10 if $R0 < r$.
4. Condition code (CC1, CC0): 01 if $r > V$, 00 if $r = V$, 10 if $r < V$.
5. Index register must be register 3 or 3'.
6. Condition code (CC1, CC0): 00 if all selected bits are 1s, 10 if not all the selected bits are 1s.

PROGRAM STATUS WORD

PSU

7	6	5	4	3	2	1	0
S	F	II	Not Used	Not Used	SP2	SP1	SP0

S Sense
 F Flag
 II Interrupt Inhibit
 SP2 Stack Pointer Two
 SP1 Stack Pointer One
 SP0 Stack Pointer Zero

PSL

7	6	5	4	3	2	1	0
CC1	CC0	IDC	RS	WC	OVF	COM	C

CC1 Condition Code One
 CC0 Condition Code Zero
 IDC Interdigit Carry
 RS Register Bank Select
 WC With/Without Carry
 OVF Overflow
 COM Logical/Arith. Compare
 C Carry/Borrow

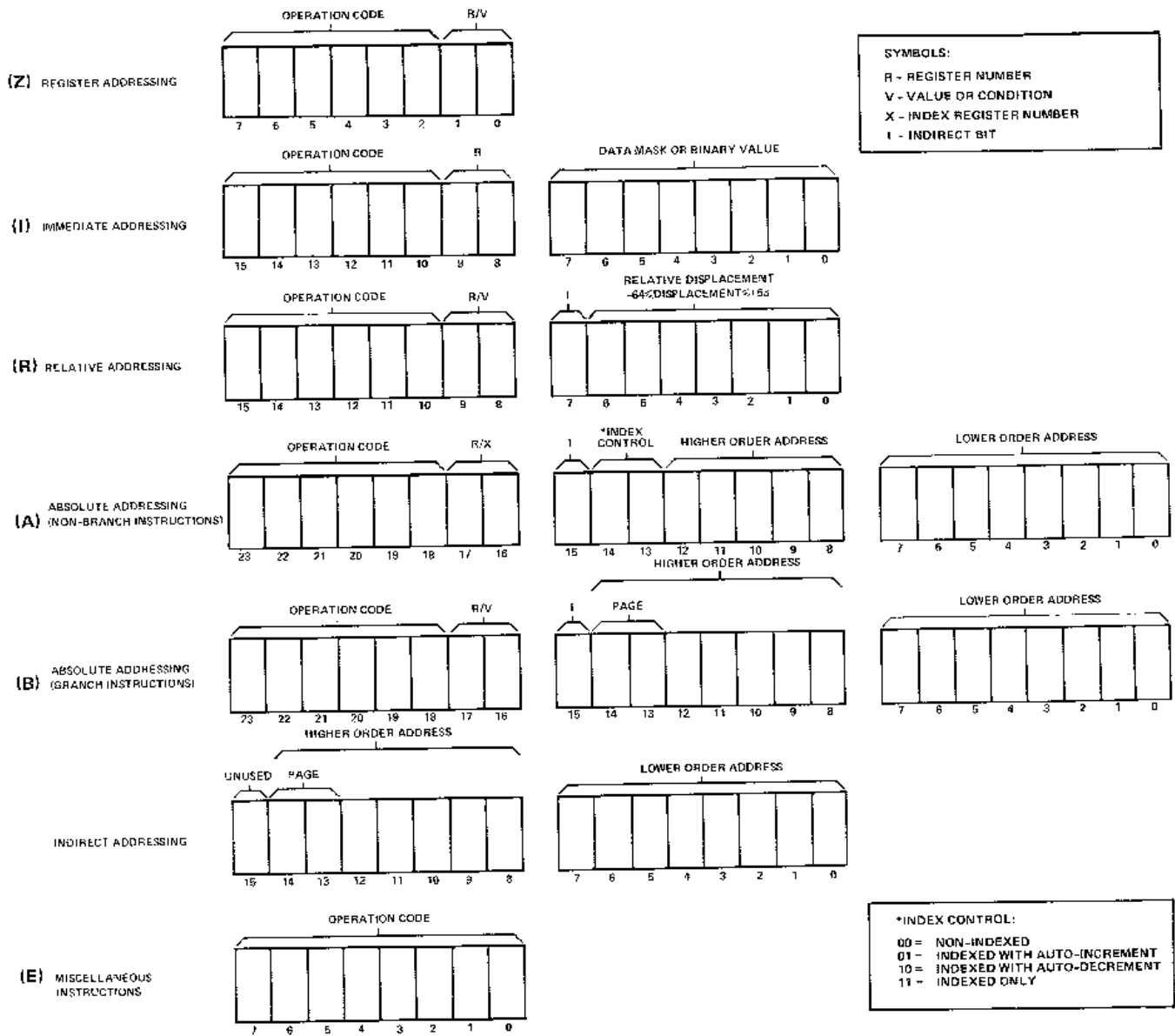

Figure 6. INSTRUCTION FORMATS

SUPPORT

DOCUMENTATION

The complete manual set is available in a durable 3-ring binder. The binder contains the Hardware Specifications, the Assembler Language Manual, the Software Simulator Manual, and a section called System Application Notes. Our update service provides customers with new application notes and updates to the manual set.

The **Hardware Specification Manual** includes a detailed description of the instruction set, the pin-outs, the AC and DC electrical characteristics, the Input/Output and memory interface signals with timing diagrams, the internal processor organization, and other useful information.

The **Assembler Language Manual** describes how to write programs in the 2650 symbolic assembly language, the pseudo-ops, and how to assemble a 2650 program. Additional information is presented on how to use the assembler program, how to interpret the output listings and how to load object modules.

The **Simulator Manual** describes the nature of the simulation program, how to write simulation commands and how to interpret the simulation output.

System Application Notes are included to help the user design with the 2650 processor. These notes present detailed technical information on various subjects of interest and apply to either programming, hardware configuration, or system concepts. This section will continue to grow.

Examples of Application Notes are:

- Serial I/O for the 2650
- Memory Interfaces
- How to use the Decimal Adjust instruction
- I/O Device Selection Methods
- A Minimal System Configuration

SOFTWARE SUPPORT

Signetics-developed software is available to both the batch processing user and the timesharing user. The Batch Assembler and Batch Simulator are written in standard FORTRAN and may be compiled and executed on most medium to large scale computer systems. Because of the modular design used, it is expected that many minicomputer users will also be able to utilize these programs. The main features of the programs are listed in Tables 3 and 4.

Signetics has also made the Batch Assembler, Batch Simulator and Interactive Simulator available on several international timesharing networks for those customers who wish to run these programs using a timesharing service.

When a customer chooses to follow the timesharing approach, he can also make use of the interactive version of the 2650 Simulator. With the Inter-

TABLE 3. ASSEMBLER FEATURES

- * 2-Pass Assembler
- * Diagnostic error messages
- * Symbolic addressing including forward references
- * Constant generation
- * Pseudo-ops to aid programming
- * Free format source code

TABLE 4. SIMULATOR FEATURES

- * Cycle Counter for timing estimates
- * Instruction fetch break points
- * Operand fetch break points
- * Trace facilities
- * Snapshot dumps
- * Patching facility
- * Statistical information generated
- * Easy-to-use command language
- * Optionally selected start and end addresses
- * Dynamic changes of simulated registers
- * Optionally simulates ROM-RAM environment

active Simulator the software designer can utilize his timesharing terminal to dynamically alter his program and effectively reduce his program development time.

The Signetics 2650 Symbolic Assembly Language has been modeled after other assembly languages; because of this, the assembler is easy to learn and to use.

The Simulator programs are designed to aid the user in testing and correcting his programs. This approach is an alternative to dedicating hardware development tools to one or two programmers or designers for program development. The Simulator allows users to simulate the execution of programs without utilizing a processor. The Simulator utilizes the object module produced by the Assembler as input, and through use of appropriate simulator commands, can display and/or alter the internal registers of the simulated 2650 processor and the simulated memory contents.

The programs are usually delivered delivered on IBM compatible magnetic tape "mini-reels". All programs are in FORTRAN source code as card image records.

A growing Program Library is available to Signetics microprocessor users. We encourage users to submit all non-proprietary programs to Signetics to add to the program library so that we may make them available to other users.

PROTOTYPING HARDWARE

PROTOTYPING CARD

In order to develop a product using the Signetics 2650 microprocessor, both hardware and software must be designed. Recognizing that the basic needs of many of our customers for prototyping systems will be similar, Signetics has designed a prototyping card containing a basic microcomputer system. This card provides a starting point for the development of hardware interfaces while simultaneously providing a tool for software checkout.

The first Signetics prototyping card consists of a 2650 processor, ROM memory containing a loader and editor, RAM memory for program storage before committing to PROM or ROM, a TTY interface for easy access, a crystal-controlled clock and two input and output ports (8 bits each).

SYSTEM COMPATIBLE FAMILIES

The 2650 has been designed to interface directly with industry standard logic and memory families, particularly 7400 and 74LS00 logic families, TTL compatible 5V NMOS memories (Signetics' 2600 series) and bipolar memories (Signetics' 8200 and 82S00 series). Many interface circuits in the 8T00 family are particularly useful for constructing interfaces in 2650 systems.

Other logic families including 8200 TTL, 82S00 STTL and 4000 CMOS are compatible with the 2650. See Table 5.

TABLE 5. SYSTEM COMPATIBLE FAMILIES

Logic	7400, 8200	-	TTL
	74LS00	-	TTL-LS
	82S00	-	STTL
	4000	-	CMOS
Memory	2500	-	PMOS
	2600	-	NMOS
	7400, 8200	-	Bipolar TTL
	82S00	-	Bipolar STTL
Interface	8T00	-	TTL, STTL

CHAPTER II

2650 HARDWARE

FEATURES

GENERAL PURPOSE PROCESSOR
SINGLE CHIP
FIXED INSTRUCTION SET
PARALLEL 8-BIT BINARY OPERATIONS
40 PIN DUAL IN-LINE PACKAGE

N-CHANNEL SILICON GATE MOS TECHNOLOGY
TTL COMPATIBLE INPUTS AND OUTPUTS
SINGLE POWER SUPPLY OF +5 VOLTS
SEVEN GENERAL PURPOSE REGISTERS
RETURN ADDRESS STACK, 8 DEEP, ON CHIP

32K BYTE ADDRESSING RANGE
SEPARATE ADDRESS AND DATA LINES
VARIABLE LENGTH INSTRUCTIONS OF 1, 2, OR 3 BYTES
75 INSTRUCTIONS
MACHINE CYCLE TIME OF $2.4\mu\text{sec}$
AT CLOCK FREQUENCY OF 1.25 MHz

DIRECT INSTRUCTIONS TAKE 2, 3 or 4 CYCLES
SINGLE PHASE TTL LEVEL CLOCK INPUT
STATIC LOGIC
TRI-STATE OUTPUT BUSES
REGISTER, IMMEDIATE, RELATIVE, ABSOLUTE
INDIRECT, AND INDEXED ADDRESSING MODES
VECTOR INTERRUPT FORMAT

INTRODUCTION

GENERAL FEATURES

The 2650 processor is a general purpose, single chip, fixed instruction set, parallel 8-bit binary processor. A general purpose processor can perform any data manipulations through execution of a stored sequence of machine instructions. The processor has been designed to closely resemble conventional binary computers, but executes variable length instructions of one to three bytes in length. BCD Arithmetic is made possible through use of a special "DAR" machine instruction.

The 2650 is manufactured using Signetics' N-channel silicon gate MOS technology. N-channel provides high carrier mobility for increased speed and also allows the use of a single 5 volt power supply. Silicon gate provides for better density and speed. Standard 40 pin dual in-line packages are used for the processor.

The 2650 contains a total of seven general purpose registers, each eight bits long. They may be used as source or destination for arithmetic operations, as index registers, and for I/O transfers.

The processor can address up to 32,768 bytes of memory in four pages of 8,192 bytes each. The processor instructions are one, two, or three bytes long, depending on the instruction. Variable length instructions tend to conserve memory space since a one-or two-byte instruction may often be used rather than a three byte instruction. The first byte of each instruction always specifies the operation to be performed and the addressing mode to be used. Most instructions use six of the first eight bits for this purpose, with the remaining two bits forming the register field. Some instructions use the full eight bits as an operation code.

The most complex direct instruction is three bytes long and takes 9.6 microseconds to execute. This figure assumes that the processor is running at its maximum clock rate, and has an associated memory with cycle and access times of one microsecond or less. The fastest instruction executes in 4.8 microseconds.

The clock input to the processor is a single phase pulse train and uses only one interface pin. It requires a normal TTL voltage swing, so no special clock driver is required.

The Data Bus and Address signals are tri-state to provide convenience in system design. Memory and I/O interface signals are asynchronous so that Direct Memory Access (DMA) and multiprocessor operations are easy to implement.

The 2650 has a versatile set of addressing modes used for locating operands for operations. They are described in detail in the INSTRUCTIONS section of this manual.

The interrupt mechanism is implemented as a single level, address vectoring type. Address vectoring means that an interrupting device can force the processor to execute code at a device determined location in memory. The interrupt mechanism is described in detail in the FEATURES section of this manual.

APPLICATIONS

The ability of the semi-conductor industry to manufacture complete general purpose processors on single chips represents a significant technological advance which should prove to be of great benefit to digital systems manufacturers. In terms of chip size and density of transistors, the processors are simply extensions of the continually evolving MOS technology. But in terms of function provided, a significant threshold has been crossed.

By allowing designers to convert from hardware logic to programmed logic, the integrated processor provides several important advantages.

1. Logic functions may be implemented in memory bits instead of logic gates. The user then has greater access to the advantages of memory circuits. Memories use patterned circuitry and thus provide greater density and therefore greater economy.
2. Random logic implementations of complex functions are highly specialized and cannot be used in other applications. They are not often used in large volume. Programmed logic, on the other hand, relies on general purpose processor and memory circuits that are used in many applications. Thus, economies of volume are available for both the user and the manufacturer.
3. Because the functional specialization resides in the user's program rather than the hardware logic, changes, corrections and additions can be much easier to make and can be accomplished in a much shorter time.
4. With the programmed logic approach it is often possible to add new features and create new products simply by writing new programs.
5. The design cycle of a system using programmed logic can be significantly shorter than a similar system that attempts to use custom random logic. The debugging cycle is also greatly compressed.

A general purpose processor designed to implement programmed logic has many characteristics that allow it to do conventional computer operations as well. Many applications will specialize in programmed logic or in data processing, but some will take advantage of both areas. In a line printer application, for example, a processor can act primarily as a controller handling the housekeeping duties, control sequencing and data interfacing for the printer. It also might buffer the data or do some code conversions, but that is not its primary duty. On the other hand, in a text editing intelligent terminal, the processor is mainly concerned with data manipulation since it handles code translations, display paging, insertions, deletions, line justification, hyphenation, etc.

A point-of-sale type of terminal represents an application that combines both control and data processing activities for the processor. Coordinating the activities of the various devices and displays that make up the terminal is an important part of the job, as are the calculations that are essential to the operation of the machine.

INTERNAL ORGANIZATION

INTERNAL REGISTERS

The block diagram for the 2650 shows the major internal components and the data paths that interconnect them. In order for the processor to execute an instruction, it performs the following general steps:

1. The Instruction Address Register provides an address for memory.
2. The first byte of an instruction is fetched from memory and stored in the Instruction Register.
3. The Instruction Register is decoded to determine the type of instruction and the addressing mode.
4. If an operand from memory is required, the operand address is resolved and loaded into the Operand Address Register.
5. The operand is fetched from memory and the operation is executed.
6. The first byte of the next instruction is fetched.

The Instruction Register (IR) holds the first byte of each instruction and directs the subsequent operations required to execute each instruction. The IR contents are decoded and used in conjunction with the timing information to control the activation and sequencing of all the other elements on the chip. The Holding Register (HR) is used in some multiple-byte instructions to contain further instruction information and partial absolute addresses.

The Arithmetic Logic Unit (ALU) is used to perform all of the data manipulation operations, including Load, Store, Add, Subtract, And, Inclusive Or, Exclusive Or, Compare, Rotate, Increment and Decrement. It contains and controls the Carry bit, the Overflow bit, the Interdigit Carry and the Condition Code Register.

The Register Stack contains six registers that are organized into two banks of three registers each. The Register Select bit (RS) picks one of the two banks to be accessed by instructions. In order to accommodate the register-to-register instructions, register zero (RO) is outside the array. Thus, register zero is always available along with one set of three registers.

The Address Adder (AA) is used to increment the instruction address and to calculate relative and indexed addresses.

The Instruction Address Register (IAR) holds the address of the next instruction byte to be accessed. The Operand Address Register (OAR) stores operand addresses and sometimes contains intermediate results during effective address calculations.

The Return Address Stack (RAS) is an eight level, Last In, First Out (LIFO) storage which receives the return address whenever a Branch-to-Subroutine instruction is executed. When a Return instruction is executed, the RAS provides the last return address for the processor's IAR. The stack contains eight levels of storage so that subroutines may be nested up to eight levels deep. The Stack Pointer (SP) is a three bit wraparound counter that indicates the next available level in the stack. It always points to the current address.

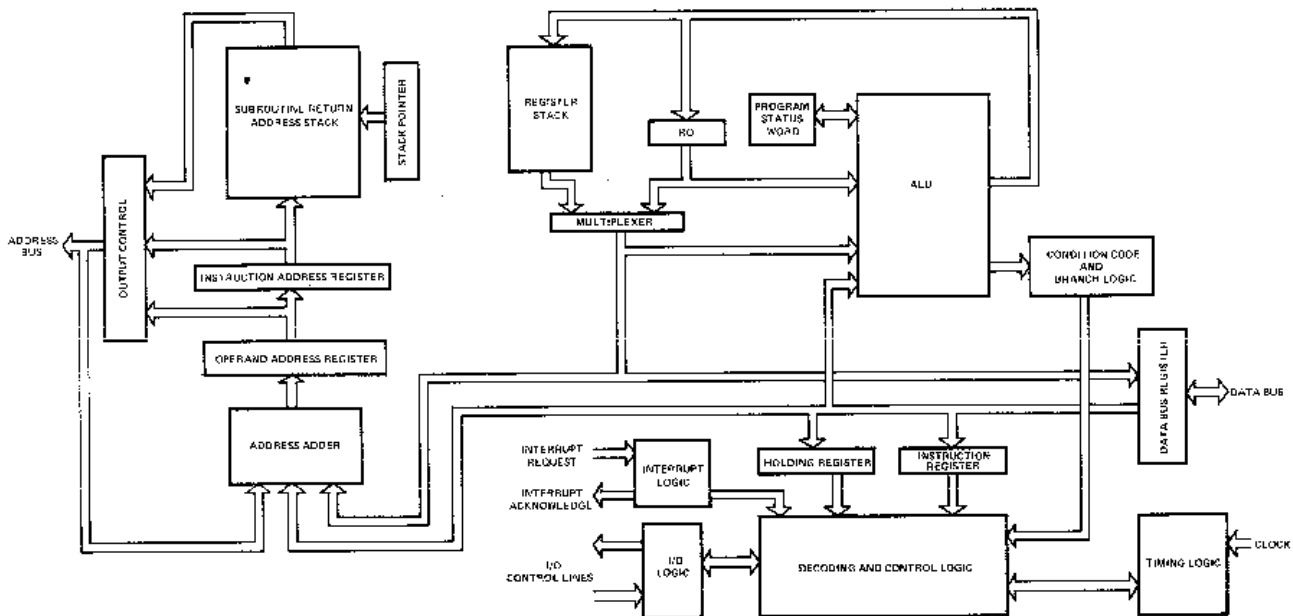

Figure 7. SIGNETICS 2650 BLOCK DIAGRAM

PROGRAM STATUS WORD

The Program Status Word (PSW) is a special purpose register within the processor that contains status and control bits. It is 16 bits long and is divided into two bytes called the Program Status Upper (PSU) and the Program Status Lower (PSL).

The PSW bits may be tested, loaded, stored, preset or cleared using the instructions which effect the PSW. The sense bit, however, cannot be set or cleared because it is directly connected to pin #1.

PSU	7	6	5	4	3	2	1	0
	S	F	II	Not Used	Not Used	SP2	SP1	SP0

- S Sense
- F Flag
- II Interrupt Inhibit
- SP2 Stack Pointer Two
- SP1 Stack Pointer One
- SP0 Stack Pointer Zero

PSL	7	6	5	4	3	2	1	0
	CC1	CC0	IDC	RS	WC	OVF	COM	C

- CC1 Condition Code One
- CC0 Condition Code Zero
- IDC Interdigit Carry
- RS Register Bank Select
- WC With/Without Carry
- OVF Overflow
- COM Logical/Arithmetic Compare
- C Carry/Borrow

SENSE (S)

The Sense bit in the PSU reflects the logic state of the sense input to the processor at pin #1. The sense bit is not affected by the LPSU, PPSU, or CPSU instructions. When the PSU is tested (TPSU) or stored into register zero (SPSU), bit #7 reflects the state of the sense pin at the time of the instruction execution.

FLAG (F)

The Flag bit is a simple latch that drives the Flag output (pin #40) on the processor.

INTERRUPT INHIBIT (II)

When the Interrupt Inhibit (II) bit is set, the processor will not recognize an incoming interrupt. When interrupts are enabled (II=0), and an interrupt signal occurs, the inhibit bit in the PSU is then automatically set. When a Return-and-Enable instruction is executed, the inhibit bit is automatically cleared.

STACK POINTER (SP)

The three Stack Pointer bits are used to address locations in the Return Address Stack (RAS). The SP designates the stack level which contains the current return address. The three SP bits are organized as a binary counter which is automatically incremented with execution of Branch-to-Subroutine instructions, and decremented with execution of Return instructions.

CONDITION CODE (CC)

The Condition Code is a two bit register which is set by the processor whenever a general purpose register is loaded or modified by the execution of an instruction. Additionally, the CC is set to reflect the relative value of two bytes whenever a compare instruction is executed.

The following table indicates the setting of the Condition Code whenever data is set into a general purpose register. The data byte is interpreted as an 8-bit, two's complement number.

Register Contents	CC1	CC0
Positive	0	1
Zero	0	0
Negative	1	0

For compare instructions the following table summarizes the setting of the CC. The data is compared as two 8-bit absolute numbers if bit #1, the COM bit, of the Program Status Lower byte is set to indicate "logical" compare (COM=1). If the COM bit indicates "arithmetic" (COM=0), the comparison instructions interpret the data bytes as two 8-bit two's complement binary numbers.

Register to Storage Compare Instruction	Register to Register Compare Instruction	CC1	CC0
Reg X Greater Than Storage	Reg 0 Greater Than Reg X	0	1
Reg X Equal to Storage	Reg 0 Equal to Reg X	0	0
Reg X Less Than Storage	Reg 0 Less Than Reg X	1	0

The CC is never set to 11 by normal processor operations, but it may be explicitly set to 11 through LPSL or PPSL instruction execution.

INTERDIGIT CARRY (DC)

For BCD arithmetic operations it is sometimes essential to know if there was a carry from bit #3 to bit #4 during the execution of an arithmetic instruction.

The IDC reflects the value of the Interdigit Carry from the previous add or subtract instruction. After any add or subtract instruction execution, the IDC contains the carry or borrow out of bit #3.

The IDC is also set upon execution of Rotate instructions when the WC bit in the PSW is set. The IDC will reflect the same information as bit #5 of the operand register after the rotate is executed. See Figure 8.

REGISTER SELECT (RS)

There are two banks of general purpose registers with three registers in each bank. The register select bit is used to specify which set of three general purpose registers will be currently used. Register zero is common and is always available to the program. An individual instruction may address only four registers, but the bank select feature effectively expands the available on-chip registers to seven. When the Register Select Bit is "0", registers 1, 2, & 3 in register bank #0 will be accessible, and when the bit is "1", registers 1, 2, & 3 in register bank #1 will be accessible.

WITH/WITHOUT CARRY(WC)

This bit controls the execution of the add, the subtract and the rotate instructions.

Whenever an add or a subtract instruction executes, the following bits are either set or cleared: Carry/Borrow (C), Overflow (OVF), and Interdigit Carry (IDC). These bits are set or reset without regard to the value of the WC bit. However, when WC=1, the final value of the carry bit affects the result of an add or a subtract instruction, i.e., the carry bit is either added (add instruction) or subtracted (subtract instruction) from the ALU.

Whenever a rotate instruction executes with WC=0, only the eight bits of the rotated register are affected. However, when WC=1, the following bits are also affected: Carry/Borrow (C), Overflow (OVF) and Interdigit Carry (IDC). The carry/borrow bit is combined with the 8-bit register to make a nine-bit rotate (see Figure 8). The overflow bit is set whenever the sign bit (bit 7) of the rotated register changes its value, i.e., from a zero (0) to a one (1) or from a one (1) to a zero (0). The interdigit carry bit is set to the new value of bit 5 of the rotated register.

OVERFLOW (OVF)

The overflow bit is set during add or subtract instruction executions whenever the two initial operands have the same sign but the result has a different sign. Operands with different signs cannot cause overflow. Example: A binary +124 (01111100) added to a binary +64 (01000000) produces a result of (10111100) which is interpreted in two's complement form as a -68. The true answer would be 188, but that answer cannot be contained in the set of 8-bit, two's complement numbers used by the processor, so the OVF bit is set.

Rotate instructions also cause OVF to be set whenever the sign of the rotated byte changes.

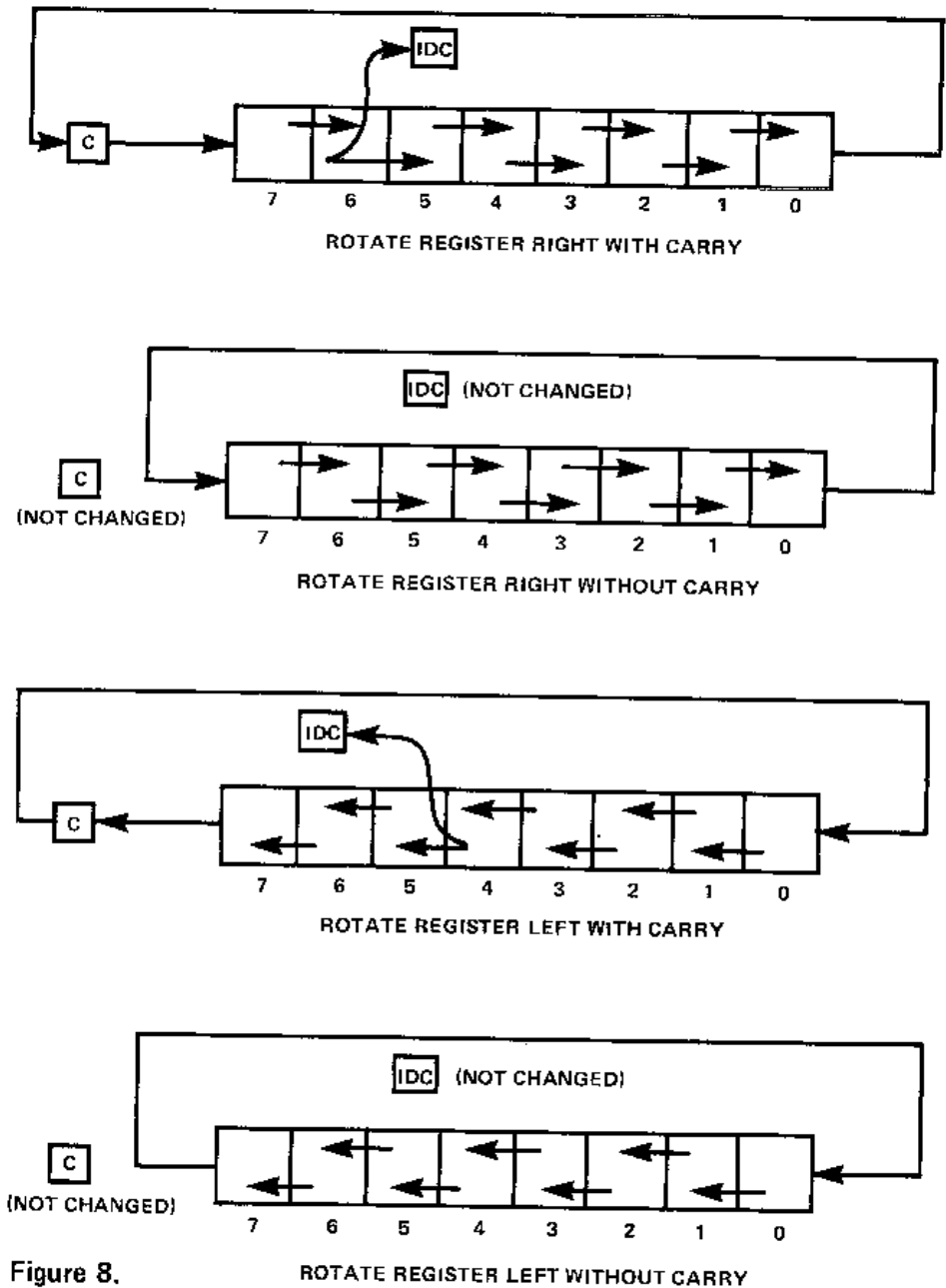

Figure 8.

ROTATE REGISTER LEFT WITHOUT CARRY

COMPARE (COM)

The compare control bit determines the type of comparison that is executed with the Compare instructions. Either logical or arithmetic comparisons may be made. The arithmetic compare assumes that the comparison is between 8-bit, two's complement numbers. The logical compare assumes that the comparison is between 8-bit positive binary numbers. When COM is set to 1, the comparisons will be logical, and when COM is set to 0, the comparisons will be arithmetic. See Condition Code (CC).

CARRY (C)

The Carry bit is set by the execution of any add or subtract instruction that results in a carry or borrow out of the high order bit of the ALU. The carry bit is set to 1 by an add instruction that generates a carry, and a subtract instruction that does *not* generate a borrow. Inversely, an add that does not generate a carry causes the C bit to be cleared, and a subtract instruction that generates a borrow also clears the carry bit.

Even though a borrow is indicated by a zero in the Carry bit, the processor will correctly interpret the zero during subtract with borrow operations as in the following table.

Low Order bit Minuend	Low Order bit Subtrahend	Carry bit Borrow bit	Low Order Bit Result
0	0	0	1
0	0	1	0
0	1	0	0
0	1	1	1
1	0	0	0
1	0	1	1
1	1	0	1
1	1	1	0

The carry bit may also be set or cleared by rotate instructions as described earlier under "With/Without Carry".

To perform an Add with Carry or a Subtract with Borrow, the WC bit must be set.

MEMORY ORGANIZATION

The 2650 has a maximum memory addressing capability of 0_{10} — $32,767_{10}$ locations. As may be seen in the INSTRUCTIONS section of this manual, most direct addressing instructions have thirteen bits allocated for the direct address. Since thirteen bits can only address locations 0_{10} — $8,191_{10}$, a paging system was implemented to accommodate the entire address range.

The memory may be thought of as being divided into four pages of 8,192 bytes each. The addresses in each page range as in the following chart:

	START ADDRESS	END ADDRESS	
page 0	00000000000000	00111111111111	0_{10} — 8191_{10}
page 1	01000000000000	01111111111111	8192_{10} — $16,383_{10}$
page 2	10000000000000	10111111111111	$16,384_{10}$ — $24,575_{10}$
page 3	11000000000000	11111111111111	$24,576_{10}$ — $32,767_{10}$

The low order 13-bits in every page range through the same set of numbers. These 13-bits are the same 13-bits addressed by non-branch instructions and are also the same 13-bits which are brought out of the 2650 on the address lines ADR0 — ADR12.

The high order two bits of the 15-bit address are known as the page bits. The page bits when examined by themselves also represent, in binary, the number of the memory page. Thus, the address 010000001101101 is known as address location 109_{10} in page 1. The page bits, corresponding to ADR13 and ADR14 are brought out of the 2650 on pins 19 & 18. These bits may be used for memory access when more than 8,192 bytes of memory are connected.

There are no instructions to explicitly set the page bits. They may be set through execution of direct or indirect, branch or branch-to-subroutine instructions. It may be seen that these instructions (see INSTRUCTION Section) have 15-bits allocated for address and when such an instruction is executed, the two high order address bits are set into the page bit latches in the 2650 processor and will appear on ADR13 and ADR14 during memory accesses until they are specifically changed.

For memory access from non-branch instructions, the 13-bit direct address will address the corresponding location within the current page only. However, the non-branch memory access instruction may access any byte in any page through indirect addressing which provides the full 15-bit address. In the case of non-branch instructions, the page bits are only temporarily changed to correspond to the high order two bits of the 15-bit indirect address used to fetch the argument byte. Immediately after the memory access, ADR13 & ADR14 will revert to their previous value.

The consequences of this page address system may be summarized by the following statements.

1. The RESET signal clears both page latches, i.e., ADR13 & ADR14 are cleared to zero.
2. All non-branch, direct memory access instructions address memory within the current page.
3. All non-branch, memory access instructions may access any byte of addressable memory through use of indirect addressing which temporarily changes the page bits for the argument access, but which revert back to their previous state immediately following instruction execution.
4. All direct and indirect addressing branch instructions set the page bits to correspond to the high order two bits of the 15 bit address.
5. Programs may *not* flow across page boundaries, they must branch to set the page bits.
6. Interrupts always drive the processor to page zero.

INTERFACE

SIGNALS

RESET

The RESET signal is used to cause the 2650 to begin processing from a known state. RESET will normally be used to initialize the processor after power-up or to restart a program. RESET clears the Interrupt Inhibit control bit, clears the internal interrupt-waiting signal, and initializes the IAR to zero. RESET is normally low during program execution, and must be driven high to activate the RESET function. The leading and trailing edges may be asynchronous with respect to the clock. The RESET signal must be at least three clock periods long. If RESET alone is used to initiate processing, the first instruction will be fetched from memory location page zero byte zero after the RESET signal is removed. Any instruction may be programmed for this location including a Branch to some program located elsewhere.

Processing can also be initiated by combining an interrupt with a reset. In this case, the first instruction to be executed will be at the interrupt address.

CLOCK

The clock signal is a positive-going pulse train that determines the instruction execution rate. Three clock periods comprise a processor cycle. Direct instructions are 2, 3, or 4 processor cycles long, depending on the specific type of instruction. Indirect addressing adds two processor cycles to the direct instruction times.

PAUSE

The $\overline{\text{PAUSE}}$ input provides a means for temporarily stopping the execution of a program. When $\overline{\text{PAUSE}}$ is driven low, the 2650 finishes the instruction in progress and then enters the WAIT state. When $\overline{\text{PAUSE}}$ goes high, program execution continues with the next instruction. If $\overline{\text{PAUSE}}$ is turned on then off again before the last cycle of the current instruction begins, program execution continues without pause. If both $\overline{\text{PAUSE}}$ and $\overline{\text{INTREQ}}$ occur prior to the last cycle of the current instruction, the interrupt will be recognized, and an INTACK will be generated immediately following release of the $\overline{\text{PAUSE}}$. The next instruction to be executed will be a ZBSR to service the interrupt.

If an $\overline{\text{INTREQ}}$ occurs while the 2650 is in a WAIT state due to a $\overline{\text{PAUSE}}$, the interrupt will be acknowledged and serviced after the execution of the next normal instruction following release of the $\overline{\text{PAUSE}}$.

INTREQ

The Interrupt Request input (normally high) is a means for external devices to change the flow of program execution. When the processor recognizes an $\overline{\text{INTREQ}}$, i.e., $\overline{\text{INTREQ}}$ is driven low, it finishes the instruction in progress, inserts a ZBSR instruction into the IR, turns on the Interrupt Inhibit bit in the PSU, and then responds with INTACK and OPREQ signals. Upon receipt of INTACK, the interrupting device may raise the $\overline{\text{INTREQ}}$ line and present a data byte to the processor on the DBUS. The required byte takes the same form as the second byte of a ZBSR instruction. Thus, the interrupt initiated Branch-to-Subroutine instruction may have a relative target address anywhere within the first or last 64 bytes of memory page 0. If indirect addressing is specified, a branch to any location in addressable memory is possible.

For devices that do not need the flexibility of the multiple target addresses, a byte of eight zeroes may be presented and will cause a direct subroutine branch to memory location zero in page zero. The relative address presented by the interrupting device is handled with a normal I/O read sequence using the usual interface control signals. The addition of the INTACK signal distinguishes the interrupt address operation from other operations that may take place as part of the execution of the interrupted instruction. At the same time that it acknowledges the $\overline{\text{INTREQ}}$, the processor automatically sets the bit that inhibits recognition of further interrupts. The Interrupt Inhibit bit may be cleared anytime during the interrupt service routine, or a Return-and-Enable instruction may be used to enable interrupts upon leaving the routine. If an $\overline{\text{INTREQ}}$ is waiting when the Interrupt Inhibit bit is cleared, it will be recognized and processed immediately without the execution of an intervening instruction.

$\overline{\text{OPACK}}$

The Operation Acknowledge signal is a reply from external memory or I/O devices as a response to the Operation Request signal from the processor. $\overline{\text{OPREQ}}$ is used to initiate an external operation. The affected external device indicates to the processor that the operation is complete by turning on the $\overline{\text{OPACK}}$ signal. This procedure allows asynchronous functioning of external devices.

If a Memory operation is initiated by the processor, the memory system will provide an $\overline{\text{OPACK}}$ when the requested memory data is valid on the Data Bus. If an I/O operation is initiated by the processor, the addressed I/O device may respond with an $\overline{\text{OPACK}}$ as soon as the write data is accepted from the Data Bus, or after the read operation is completed. However, in order to avoid slowing down the processor when using memories or I/O devices that are just fast enough to keep the processor operating at full speed the $\overline{\text{OPACK}}$ signal must be returned before the external operation is completed. Any $\overline{\text{OPACK}}$ that is returned within 600 nsec. following an $\overline{\text{OPREQ}}$ will not delay the processor. Data from a read operation can return up to 1000 nsec. after an $\overline{\text{OPREQ}}$ is sent and still be accepted by the processor without causing delays. If all devices will always respond within these time limits, the $\overline{\text{OPACK}}$ line may be permanently connected in the ON (low) state. Whenever an $\overline{\text{OPACK}}$ is not available within that time, the processor will delay instruction execution until the first clock following receipt of the $\overline{\text{OPACK}}$. All output line conditions remain unchanged during the delay and the processor does not enter the WAIT state. $\overline{\text{OPACK}}$ is true in the low state and false in the high state.

SENSE

The SENSE line provides an input line to the 2650 that is independent of the normal I/O Bus structures. The SENSE signal is connected directly to one of the bits in the Program Status Word. It may be stored or tested by an executing program. When a store (SPSU) or test (TPSU) instruction is executed, the SENSE line is sampled during the last cycle of the instruction.

Through proper programming techniques the SENSE signal may be used to implement a direct serial data input channel, or it may be used to present any bit of information that the designer chooses.

The SENSE input and FLAG output facilities provide the simplest method of communicating data in or out of the 2650 Processor as neither address decoding nor synchronization with other processor signals is necessary.

ADREN

The Address Enable signal allows external control of the tri-state address outputs (ADR0-ADR12). When $\overline{\text{ADREN}}$ is driven high, the address lines are switched to their third state and show a high output impedance. This feature allows wired-OR connections with other signals. The ADR13 and ADR14 lines which are multiplexed with other signals are not affected by this signal.

When a system is not designed to utilize the feature, the $\overline{\text{ADREN}}$ input may be connected permanently to a low signal source.

DBUSEN

The Data Bus Enable signal allows external control of the tri-state Data Bus output drivers. When $\overline{\text{DBUSEN}}$ is driven high, the Data Bus will exhibit a high output impedance. This allows wired-OR connection with other signals.

When a system is not designed to utilize this feature, the $\overline{\text{DBUSEN}}$ input may be permanently connected to a low signal source.

DBUS

The Data Bus signals form an 8-bit bi-directional data path in and out of the processor. Memory and I/O operations use the Data Bus to transfer the write or read data to or from memory.

The direction of the data flow on the Data Bus is indicated by the state of the $\overline{\text{R/W}}$ line. For Write operations, the output buffers in the processor output data to the bus for use by memory or by external devices. For Read operations, the buffers are disabled and the data condition of the bus is sensed by the processor. The output buffers may also be disabled by the $\overline{\text{DBUSEN}}$ signal.

The signals on the data bus are true signals, i.e., a one is a high level and a zero is low.

ADR

The Address signals form a 15 bit path out of the processor, and are used primarily to supply memory addresses during memory operations. The addresses remain valid as long as $\overline{\text{OPREQ}}$ is on so that no external address register is required. For extended I/O operations, the low order eight bits of the ADR lines are used to output the immediate byte of the instruction which typically is interpreted as a device address.

The 13 low order lines of the address are used only for address information. The two high order address lines are multiplexed with I/O control information. During memory operations, the lines serve as memory addresses. During I/O operations they serve as the $\overline{\text{D/C}}$ and $\overline{\text{E/NE}}$ control lines. Demultiplexing is accomplished through use of the Memory/ $\overline{\text{IO}}$ Control line.

The line ADR0 carries the low order address bit, and ADR12 carries the high order address bit. The output drivers may be disabled by the $\overline{\text{ADREN}}$ signal.

The signals on the address bus are true, i.e., a one is a high level and a zero is low.

OPREQ

The Operation Request output is the coordinating signal for all external operations. The $\overline{\text{M/IO}}$, $\overline{\text{R/W}}$, $\overline{\text{E/NE}}$, $\overline{\text{D/C}}$ and INTACK lines are operation control signals that describe the nature of the external operation when the $\overline{\text{OPREQ}}$ line is true. The DBUS and ADR bus also should not be considered

valid except when OPREQ is in the high, or on state.

No output signals from the processor will change as long as OPREQ is on, with the exception of WRP. OPREQ will stay on until the external operation is complete, as indicated by the $\overline{\text{OPACK}}$ input. The processor delays all internal activity following an OPREQ until the $\overline{\text{OPACK}}$ signal is received.

INTACK

The Interrupt Acknowledge signal is used by the processor to respond to an external interrupt. When an $\overline{\text{INTREQ}}$ is received, the current instruction is completed before the interrupt is serviced. When the processor is ready to accept the interrupt it sets the INTACK to the high, or on, state along with OPREQ. The interrupting device then presents a relative address byte to the DBUS and responds with an $\overline{\text{OPACK}}$ signal. $\overline{\text{INTREQ}}$ may be turned off anytime following INTACK. INTACK will fall after the processor receives the $\overline{\text{OPACK}}$ signal.

M/ $\overline{\text{IO}}$

The Memory/ $\overline{\text{IO}}$ output is one of the operation control signals that defines external operations. M/ $\overline{\text{IO}}$ indicates whether an operation is memory or I/O and should be used to gate Read or Write signals between memory or I/O devices.

The state of M/ $\overline{\text{IO}}$ will not change while OPREQ is high.

The high state corresponds to Memory operation, and the low state corresponds to an I/O operation.

$\overline{\text{R/W}}$

The Read/Write output is one of the operation control signals that defines external operations. $\overline{\text{R/W}}$ indicates whether an operation is *Read* or *Write*. It controls the nature of the external operation and indicates in which direction the DBUS is pointing. $\overline{\text{R/W}}$ should not be considered valid until OPREQ is on and the state of the $\overline{\text{R/W}}$ line does not change as long as OPREQ is on.

The high state corresponds to the Write operation, and the low state corresponds to the Read operation.

D/ $\overline{\text{C}}$

The Data/Control Output is an I/O signal which is used to discriminate between the execution of the two types of one byte I/O instructions. There are four one byte I/O instructions; WRTC, WRTD, REDC, REDD. When Read Control or Write Control is executed, the D/ $\overline{\text{C}}$ line takes on the low state which indicates Control ($\overline{\text{C}}$). When Read Data or Write Data is executed, the D/ $\overline{\text{C}}$ line takes on the high state, indicating Data (D).

D/ $\overline{\text{C}}$ should not be considered valid until (a) OPREQ is on and (b) M/ $\overline{\text{IO}}$ indicates an I/O operation and (c) E/ $\overline{\text{NE}}$ indicates a non-extended (one byte) operation. D/ $\overline{\text{C}}$ is multiplexed with a high order address line. When the M/ $\overline{\text{IO}}$ line is in the I/O state, the ADR14-D/ $\overline{\text{C}}$ line should be interpreted as "D/ $\overline{\text{C}}$ ". (When the M/ $\overline{\text{IO}}$ line is in the M state, the ADR14-D/ $\overline{\text{C}}$ line should be interpreted as memory address line #14.)

E/\overline{NE}

The Extended/Non-Extended output is the operation control signal that is used to discriminate between two byte and one byte I/O operations. Thus, E/\overline{NE} indicates the presence or absence of valid information on the eight low order address lines during I/O operations.

E/\overline{NE} should not be considered valid until (a) $OPREQ$ is on and (b) M/\overline{IO} indicates an I/O operation. E/\overline{NE} is multiplexed with a high order address line. When the M/\overline{IO} line is in the I/O state, the $ADR13-E/\overline{NE}$ line should be interpreted as " E/\overline{NE} ". (When the M/\overline{IO} line is in the M state, the $ADR13-E/\overline{NE}$ line should be interpreted as memory address bit #13.)

There are six I/O instructions; $REDE$, $WRTE$, $REDC$, $REDD$, $WRTE$, $WRTE$, $WRTE$. When either of the two byte I/O instructions is executed ($REDE$, $WRTE$), the E/\overline{NE} line takes on the high state or "Extended" indication. When any of the one byte I/O instructions is executed, the line takes on the low state or "non-extended" indication.

RUN/\overline{WAIT}

The RUN/\overline{WAIT} output signal indicates the Run/Wait Status of the processor. The $WAIT$ state may be entered by executing a $HALT$ instruction or by turning on the \overline{PAUSE} input. At any other time the processor will be in a RUN state.

When the processor is executing instructions, the line is in the high or RUN state; when in the $WAIT$ state, the line is held low.

The $HALT$ initiated $WAIT$ condition can be changed to RUN by a $RESET$ or an interrupt. The \overline{PAUSE} initiated $WAIT$ condition can be changed to RUN by removing the \overline{PAUSE} input.

If a $RESET$ occurs during a \overline{PAUSE} initiated $WAIT$ state and the \overline{PAUSE} remains low; the processor will be reset, fetch one instruction from page zero byte zero and return to the $WAIT$ state. When the \overline{PAUSE} is eventually removed, the previously fetched instruction will be executed.

FLAG

The $FLAG$ output indicates the state of the Flag bit in the PSW . Any change in the Flag bit is reflected by a change in the $FLAG$ output. A one bit in the Flag will give a high level on the $FLAG$ output pin. The $LPSU$, $PPSU$, and $CPSU$ instructions can change the state of the Flag bit. The $FLAG$ output is always a valid indication of the state of the Flag bit without regard for the status of the processor or control signals. Changes in the Flag bit are synchronized with the last cycle of the changing instruction.

WRP

The Write Pulse output is a timing signal from the processor that provides a positive-going pulse in the middle of each requested write operation (memory or I/O) and a high level during read operations. The WRP is designed to be used with Signetics 2606 R/W memory circuits to provide a timed Chip Enable signal. For use with memory, it may be gated with the M/\overline{IO} signal to generate a Memory Write Pulse.

Because the WRP pulse occurs during any write operation, it may also be used with I/O write operations where convenient.

SIGNAL TIMING

The Clock input to the 2650 provides the basic timing information that the processor uses for all its internal and external operations. The clock rate determines the instruction execution rate, except to the extent that external memories and devices slow down the processor. Each internal processor cycle is composed of three clock periods as shown in Figure 9, 2650 TIMING DIAGRAMS.

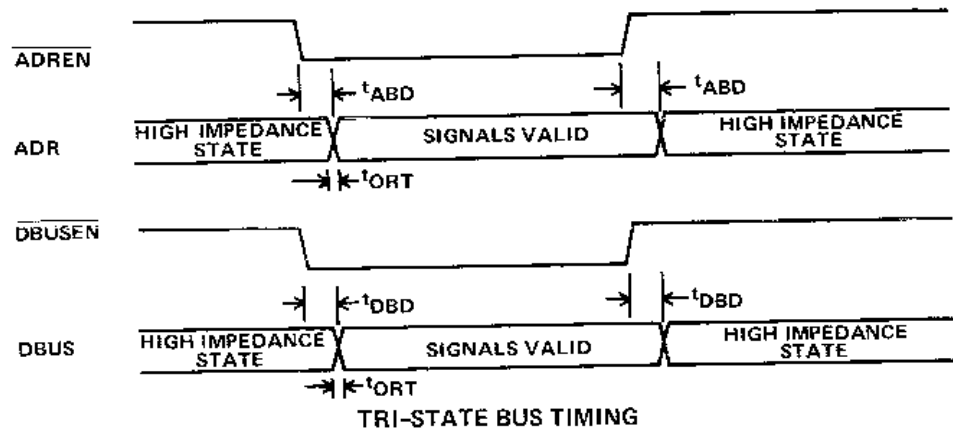
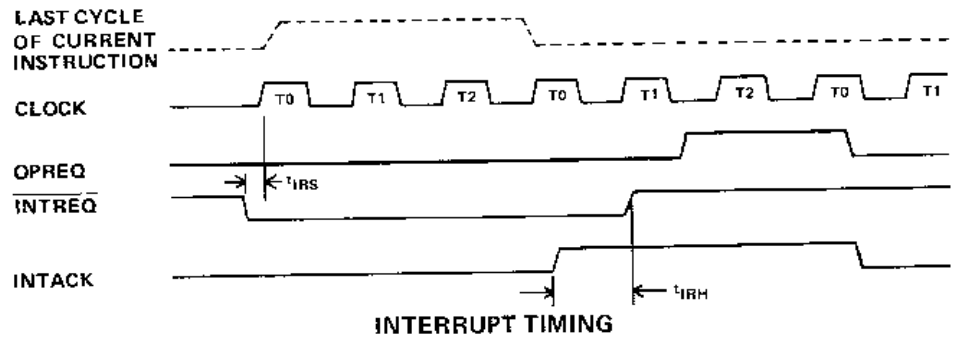
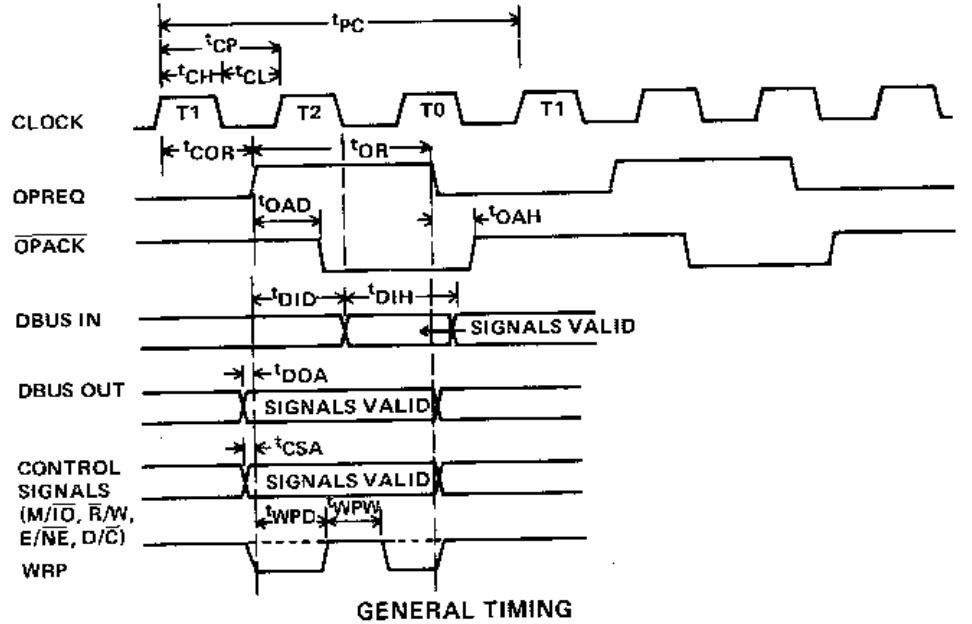

Figure 9. 2650 TIMING DIAGRAMS

OPREQ is the master control signal that coordinates all operations external to the processor. Many of the other signal interactions are related to OPREQ. The timing diagram assumes that the clock periods are constant and that $\overline{\text{OPACK}}$ is returned in time to avoid delaying instruction execution. In that case, OPREQ will be high for 1.5 clock periods ($1/2$ of t_{pc}) and then will be low for another 1.5 clock periods.

The interface control signals have been designed to implement asynchronous interfaces for both memory and input/output devices. The control signals are relatively simple and provide the following advantages: no external synchronizing is necessary, external devices may run at any data rate up to the processor's maximum I/O data rate, and because data signals are furnished with guard signals the external devices are often relieved of the necessity of latching information such as memory address.

MEMORY READ TIMING

The following signals are involved in the processor's memory read sequence, as shown in Figure 10.

OPREQ	= Operation Request
DBUS0-DBUS7*	= Data Bus
ADR0-ADR12	= Address Bus
ADR13	= Address bit 13
ADR14	= Address bit 14
$M/\overline{\text{IO}}$	= Memory/Input-Output
$\overline{\text{R}}/\text{W}$	= Read/Write
$\overline{\text{OPACK}}^*$	= Operation Acknowledge

The signals marked with an asterisk are sent from the memory device to the processor. The other signals are developed by the processor.

OPREQ is a guard signal which must be valid (high) for the other signals to have meaning. When reading main memory the 2650 simultaneously switches OPREQ to a high state, $M/\overline{\text{IO}}$ to M (memory), $\overline{\text{R}}/\text{W}$ to $\overline{\text{R}}$ (Read), and places the memory address on lines ADR0-ADR14. Remember that

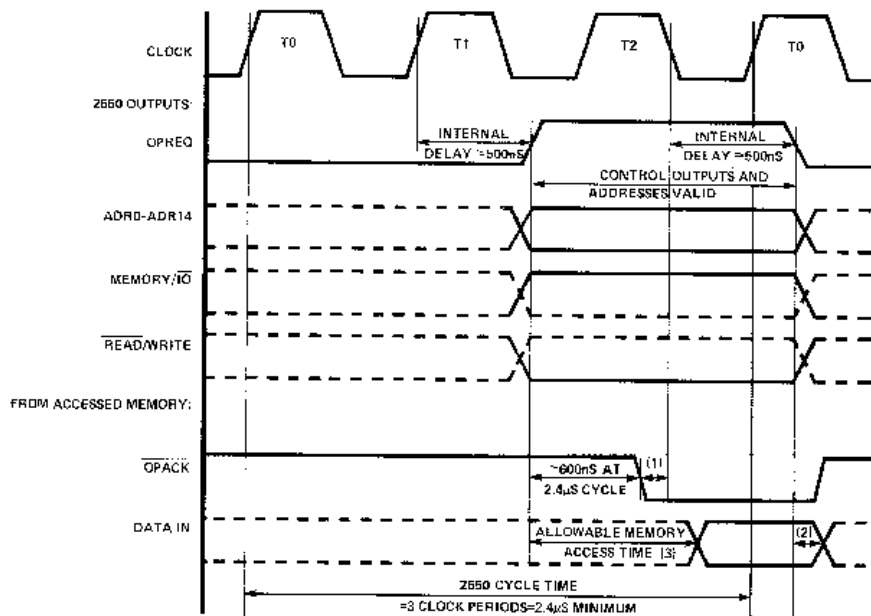

- NOTES: (1) OPACK must go low at least 100 ns before the trailing edge of T2 in order not to slow down the 2650.
 (2) DATA IN signals must be valid for 50ns after the trailing edge of OPREQ.
 (3) Allowable memory access time is 1us with 2.4us cycle time.

Figure 10. MEMORY READ SEQUENCE

ADR13 & ADR14 are multiplexed with other signals and must be logically ANDed with OPREQ and M to be interpreted. Of course, ADR13 & ADR14 may be ignored if only page zero (8,192 bytes) is used.

Once the memory logic has determined the simultaneous existence of the signals mentioned above, it places the true data corresponding to the given address location on the data bus (DBUS0 to DBUS7), and returns an $\overline{\text{OPACK}}$ signal to the processor. The processor, recognizing the $\overline{\text{OPACK}}$, strobes the data into the receiving register and lowers the OPREQ. This completes the memory read sequence.

If the $\overline{\text{OPACK}}$ signal is delayed by the memory device, the processor waits until it is received. OPREQ is lowered only after the receipt of $\overline{\text{OPACK}}$. The memory device should raise $\overline{\text{OPACK}}$ after OPREQ falls.

MEMORY WRITE TIMING

The signals involved with the processor's memory write sequence are similar to those used in the memory read sequence with the following exceptions: 1) the $\overline{\text{R/W}}$ signal is in the W state and, 2) the WRP signal provides a positive going pulse during the write sequence which may be used as a chip enable, write pulse, etc.

Figure 11 demonstrates the signals that occur during a memory write.

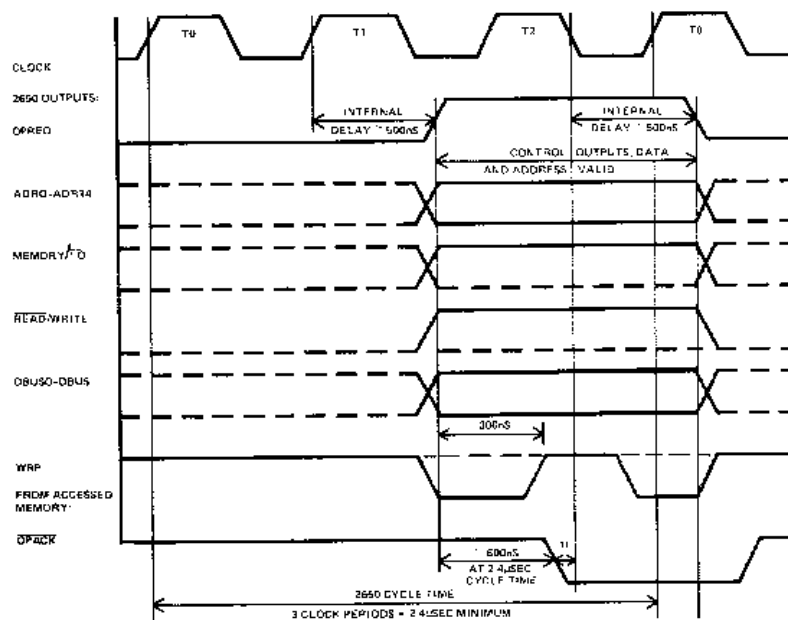

NOTES: (1) $\overline{\text{OPACK}}$ must go low at least 100ns before the trailing edge of T2 in order not to slow down the 2690.

Figure 11. MEMORY WRITE SEQUENCE

INPUT/OUTPUT TIMING

The signal exchanges for I/O with external devices is very similar to the signaling for memory read/write. See the Features Section, INPUT/OUTPUT FACILITIES.

CRITICAL TIMES

Figure 9 describes the timing relationship between the various interface signals. The critical times are labeled and defined in the table of AC characteristics.

ELECTRICAL CHARACTERISTICS

PRELIMINARY AC CHARACTERISTICS

$T_A = 0^\circ\text{C}$ to 70°C $V_{CC} = 5V \pm 5\%$ unless otherwise specified, see notes 1,2,3 & 4.

SYMBOL	PARAMETER	LIMITS		UNITS
		MIN	MAX	
t_{CH}	Clock High Phase	400	10,000	nsec
t_{CL}	Clock Low Phase	400	∞	nsec
t_{CP}	Clock Period	800	∞	nsec
t_{PC}^6	Processor Cycle Time	2,400	∞	nsec
t_{OR}	OPREQ Pulse Width	$2t_{CH} + t_{CL} - 100$	∞	nsec
t_{COR}	Clock to OPREQ Time	100	700	nsec
t_{OAD}^7	OPACK Delay Time	0	∞	nsec
t_{OAH}	OPACK Hold Time	0	∞	nsec
t_{CSA}	Control Signal Available	50		nsec
t_{DOA}	Data Out Available	50		nsec
t_{DID}^8	Data in Delay	0	1000(8)	nsec
t_{DIH}^9	Data in Hold	150		nsec
t_{WPD}	Write Pulse Delay	$t_{CL} - 100$	$t_{CL} - 50$	nsec
t_{WPW}	Write Pulse Width	t_{CL}	t_{CL}	nsec
t_{ABD}	Address Bus Delay		80	nsec
t_{DBD}	Data Bus Delay		120	nsec
t_{IRS}^{10}	INTREQ Set up Time	0		nsec
t_{IRH}^{10}	INTREQ Hold Time	0		nsec
t_{ORT}^5	Output Buffer Rise Time		150	nsec

NOTES ON AC CHARACTERISTICS

1. See preceding timing diagrams for definition of timing terms.
2. Input levels swing between 0.65 volt and 2.2 volts.
3. Input signal transition times are 20ns.
4. Timing reference level is 1.5 volts.
5. Load is $-100\mu\text{A}$ at 20pF.
6. A Processor Cycle time consists of three clock periods.
7. In order to avoid slowing down the processor, $\overline{\text{OPACK}}$ must be lowered 100ns before the trailing edge of T2 clock, if $\overline{\text{OPACK}}$ is delayed past this point, the processor will wait in the T2 state and sample $\overline{\text{OPACK}}$ on each subsequent negative clock edge until $\overline{\text{OPACK}}$ is lowered.
8. In order to avoid slowing the processor down, input data must be returned to the processor in $1\mu\text{s}$ or less time from the OPREQ edge, at a cycle time of $2.4\mu\text{s}$.
9. Input data must be held until 50ns after OPREQ falls.
10. In order to interrupt the current instruction, $\overline{\text{INTREQ}}$ must fall prior to the first clock of the last cycle of the current instruction. $\overline{\text{INTREQ}}$ must remain low until INTACK goes high.

MAXIMUM GUARANTEED RATINGS⁽¹⁾

Operating Ambient Temperature	0°C to +70°C
Storage Temperature	-65°C to +150°C
All Input, Output, and Supply Voltages with respect to ground pin ⁽³⁾	-0.5V to +6V
Package Power Dissipation ⁽²⁾ =1W/pkg.	1.6W

PRELIMINARY 2650 DC ELECTRICAL CHARACTERISTICS

SYMBOL	PARAMETER	TEST CONDITIONS	LIMITS		UNIT
			MIN	MAX	
I _{LI}	Input Load Current	V _{IN} = 0 to 5.25V		10	μA
I _{LOH}	Output Leakage Current	ADREN, DBUSEN = 2.2V, V _{OUT} = 4V		10	μA
I _{LOL}	Output Leakage Current	ADREN, DBUSEN = 2.2V, V _{OUT} = 0.45V		10	μA
I _{CC}	Power Supply Current	V _{CC} = 5.25V, T _A = 0°C		100	mA
V _{IL}	Input Low		-0.6	0.8	V
V _{IH}	Input High		2.2	V _{CC}	V
V _{OL}	Output Low	I _{OL} = 1.6 mA	0.0	0.45	V
V _{OH}	Output High	I _{OH} = -100 μA	2.4	V _{CC} -0.5	V
C _{IN}	Input Capacitance	V _{IN} = 0V		10	pF
C _{OUT}	Output Capacitance	V _{OUT} = 0V		10	pF

Conditions: T_A = 0°C to 70°C, V_{CC} = 5V ±5%

NOTES:

- Stresses above those listed under "Maximum Guaranteed Ratings" may cause permanent damage to the device. This is a stress rating only and functional operation of the device at these or at any other condition above those indicated in the operation sections of this specification is not implied.
- For operating at elevated temperatures the device must be derated based on a +150°C maximum junction temperature and a thermal resistance of 50°C/W junction to ambient (40 pin 1W package).
- This product includes circuitry specifically designed for the protection of its internal devices from the damaging effects of excessive static charge. Nonetheless, it is suggested that conventional precautions be taken to avoid applying any voltages larger than the rated maxima.
- Parameter valid over operating temperature range unless otherwise specified.
- All voltage measurements are referenced to ground.
- Manufacturer reserves the right to make design and process changes and improvements.
- Typical values are at +25°C, nominal supply voltages, and nominal processing parameters.

INTERFACE SIGNALS

TYPE	PINS	ABBREVIATION	FUNCTION	SIGNAL SENSE
INPUT	1	GND	Ground	GND=0
INPUT	?	V _{CC}	+5 Volts ±5%	V _{CC} =1
INPUT	1	RESET	Chip Reset	RESET=1 (pulse), causes reset
INPUT	1	CLOCK	Chip Clock	
INPUT	1	PAUSE	Temp. Halt execution	PAUSE=0, temporarily halts execution
INPUT	1	INTREQ	Interrupt Request	INTREQ=0, requests interrupt
INPUT	1	OPACK	Operation Acknowledge	OPACK=0, acknowledges operation
INPUT	1	SENSE	Sense	SENSE=0 (low) or SENSE=1 (high)
INPUT	1	ADREN	Address Enable	ADREN=1 drives into third state
INPUT	1	DBUSEN	Data Bus Enable	DBUSEN=1 drives into third state
IN/OUT	8	DBUS0-DBUS7	Data Bus	DBUSn=0 (low), DBUSn=1 (high)
OUTPUT	13	ADR0-ADR12	Address 0 through 12	ADRn=0 (low), ADRn=1 (high)
OUTPUT	1	ADR13 or E/NE	Address 13 or Extended/Non-Extended	Non-Extended=0, Extended=1
OUTPUT	1	ADR14 or D/C	Address 14 or Data Control	Control=0, Data=1
OUTPUT	1	OPREQ	Operation Request	OPREQ=1, requests operation
OUTPUT	1	M/I \bar{O}	Memory/IO	IO=0, M=1
OUTPUT	1	R/W	Read/Write	R=0, W=1
OUTPUT	1	FLAG	Flag Output	FLAG=1 (high), FLAG=0 (low)
OUTPUT	1	INTACK	Interrupt Acknowledge	INTACK=1, acknowledges interrupt
OUTPUT	1	RUN/WAIT	Run/Wait Indicator	RUN=1, WAIT=0
OUTPUT	1	WRP	Write Pulse	WRP=1 (pulse), causes writing

PIN CONFIGURATION

SENSE	1		40	FLAG
ADR 12	2		39	V _{CC}
ADR 11	3		38	CLOCK
ADR 10	4		37	PAUSE
ADR 9	5		36	OPACK
ADR 8	6		35	RUN/WAIT
ADR 7	7		34	INTACK
ADR 6	8		33	DBUS 0
ADR 5	9	2850	32	DBUS 1
ADR 4	10		31	DBUS 2
ADR 3	11		30	DBUS 3
ADR 2	12		29	DBUS 4
ADR 1	13		28	DBUS 5
ADR 0	14		27	DBUS 6
ADREN	15		26	DBUS 7
RESET	16		25	DBUSEN
INTREQ	17		24	OPREQ
ADR 14-D/C	18		23	R/W
ADR 13-E/NE	19		22	WRP
M/I \bar{O}	20		21	GND

TOP VIEW

FEATURES

INPUT/OUTPUT FACILITIES

The 2650 processor provides several mechanisms for performing input/output functions. They are flag and sense, non-extended I/O instructions, extended I/O instructions, and memory I/O. These four facilities are described below.

FLAG & SENSE I/O

The 2650 has the ability to directly output one bit of data without additional address decoding or synchronizing signals.

The bit labeled "Flag" in the Program Status Word is connected through a TTL compatible driver to the chip output at pin #40. The Flag output always reflects the value in the Flag bit.

When a program changes the Flag bit through execution of an LPSU, PPSU, or CPSU, the bit will be set or cleared during the last cycle of the instruction that changes it.

The Flag bit may be used conveniently for many different purposes. The following is a list of some possible uses:

1. A serial output channel
2. An additional address bit to increase addressing range.
3. A switch or toggle output to control external logic.
4. The origin of a pulse for polling chains of devices.

The Sense bit performs the complementary function of the Flag and is a single bit direct input to the 2650. The Sense input, pin #1 is connected to a TTL compatible receiver and is then routed directly to a bit position in the Program Status Word. The bit in the PSW always represents the value of the external signal. It may be sampled anytime through use of the TPSU or SPSU instructions.

This simple input to the processor may be used in many ways. The following is a list of some possible uses:

1. A serial input channel
2. A sense switch input
3. A break signal to a processing program
4. An input for yes/no signaling from external devices.

NON-EXTENDED I/O

There are four one byte I/O instructions; REDC, REDD, WRTC, and WRTD. They are all referred to as non-extended because they can communicate only one byte of data, either into or out of the 2650.

REDC and REDD causes the input transfer of one byte of data. They are identical except for the fact that the D/\bar{C} Signal is in the D state for REDD and in the \bar{C} state for REDC. Similarly, the instructions WRTC and WRTD cause an output transfer of one byte of data. The D/\bar{C} line discriminates between the two pairs of input/output instructions. The D/\bar{C} line can be used as a 1-bit device address in simple systems.

The read and write timing sequences for the one byte I/O instructions are the same as the memory read and write sequences with the following exceptions: the $M/\bar{I}O$ signal is switched to $\bar{I}O$, the D/\bar{C} line becomes valid, $E/\bar{N}E$ is switched to $\bar{N}E$ (non-extended), and the Address bus contains no valid information.

The \overline{NE} signal informs the devices outside the 2650 that a one byte I/O instruction is being executed. The D/C line indicates which pair of the one byte I/O instructions are being executed; D implies either WRD or REDD, and \overline{C} implies either WRTC or REDC. Finally, to determine whether it is a read or a write, examine the $\overline{R/W}$ signal level.

Table 6 illustrates the sense of the interface signals. The "Signal Timing" section should be referenced for the exact timing relationships. It should be remembered that the control signals are not to be considered valid except when the OPREQ signal is valid.

TABLE 6. I/O INTERFACE SIGNALS

	OPREQ	M/ \overline{IO}	$\overline{R/W}$	ADR13-E/ \overline{NE}	ADR14-D/ \overline{C}
MEMORY READ	T	M	\overline{R}	ADR13	ADR14
MEMORY WRITE	T	M	W	ADR13	ADR14
2 BYTE READ	T	\overline{IO}	\overline{R}	E	Don't Care
2 BYTE WRITE	T	\overline{IO}	W	E	Don't Care
1 BYTE CONTROL READ	T	\overline{IO}	\overline{R}	\overline{NE}	\overline{C}
1 BYTE CONTROL WRITE	T	\overline{IO}	W	\overline{NE}	\overline{C}
1 BYTE DATA READ	T	\overline{IO}	\overline{R}	\overline{NE}	D
1 BYTE DATA WRITE	T	\overline{IO}	W	\overline{NE}	D

EXTENDED I/O

There are two, two byte I/O instructions; REDE and WRTE. They are referred to as extended because they can communicate two bytes of data when they are executed. The REDE causes the second byte of the instruction to be output on the low order address lines, ADR0-ADR7, which is intended to be used as a device address while the byte of data then on the Data Bus will be strobed into the register specified in the instruction. The WRTE also presents the second byte of the instruction on the Address Bus, but a byte of data from the register specified in the instruction is simultaneously output on the Data Bus.

The two byte I/O instructions are similar to the one byte I/O instructions except: the D/ \overline{C} line is not considered, and the data from the second byte of the I/O instruction appears on the Address Bus all during the time that OPREQ is valid. The data on the Address Bus is intended to convey a device address, but may be utilized for any purpose.

Table 6 illustrates the sense of the interface signals for extended I/O instructions. Refer to "Signal Timing" section for exact timing relationships.

MEMORY I/O

The 2650 user may choose to transfer data into or out of the processor using the memory control signals. The advantage to this technique is that the data can be read or written by the program through ordinary instruction execution and data may be directly operated upon with the arithmetic instructions.

To make use of this technique, the designer has to assign memory addresses to devices and design the device interfaces to generate the same signals as memory.

A disadvantage to this method is that it may be necessary to decode more address lines to determine the device address than with other I/O facilities.

INTERRUPT MECHANISM

The 2650 has been implemented with a conventional, single level, address vectoring interrupt mechanism. There is one interrupt input pin. When an external device generates an interrupt signal ($\overline{\text{INTREQ}}$), the processor is forced to transfer control to any of 128 possible memory locations as determined by an 8-bit vector supplied by the interrupting device.

Of special interest is that the device may return a relative indirect address signal which causes the processor to enter an indirect addressing sequence upon receipt of an interrupt. This enables a device to direct the processor to execute code anywhere within addressable memory.

Upon recognizing the interrupt signal, the processor automatically sets the Interrupt Inhibit bit in the Program Status Word. This inhibits further interrupts from being recognized until the interrupt routine is finished executing and a Return-and-Enable instruction is executed or the inhibit bit is explicitly cleared.

When the inhibit bit in the PSW is set, the processor will not recognize an interrupt input. The Interrupt Inhibit bit may be set under program control (LPSU, PPSU) and is automatically set whenever the processor accepts an interrupt. The inhibit bit may be cleared in three ways:

1. By a RESET operation
2. By execution of an appropriate clear or load PSU instruction; (CPSU, LPSU)
3. By execution of a Return-and-Enable instruction.

The sequence of events for a normal interrupt operation is as follows:

1. An executing program enables interrupts.
2. External device initiates interrupt with the $\overline{\text{INTREQ}}$ line.
3. Processor finishes executing current instruction.
4. Processor sets inhibit bit.
5. Processor inserts the first byte of ZBSR (Zero Branch-to-Subroutine, Relative) instruction into the instruction register instead of what would have been the next sequential instruction.
6. Processor accesses the data bus to fetch the second byte of the ZBSR instruction.
7. Interrupting device responds to the Processor generated INTACK (Interrupt Acknowledge) by supplying the requested second byte.
8. The processor executes the Zero Branch-to-Subroutine instruction, saving the address of the instruction following the interrupted instruction in the RAS, and proceeds to execute the instruction at page 0, byte 0, or the address relative to page 0, byte 0 as given by the interrupting device.
9. When the interrupt routine is complete, a return instruction (RETC, RETE) pulls the address from the RAS and execution of the interrupted program resumes.

Since the interrupting device specifies the interrupt subroutine address in the standard relative address format, it has considerable flexibility with regard to the interrupt procedure. It can point to any location that is within +63 or -64 bytes of page zero, byte zero of memory. (Negative relative addresses wrap around the memory, modulo $8,192_{10}$ bytes.) The interrupting device also may specify whether the subroutine address is direct or indirect by providing a zero or one to DBUS #7 (pin #26). If the external device is not complex enough to exercise these options, it may respond to the INTACK operation with a byte of all zeroes. In such a case, the processor will execute a direct Branch-to-Subroutine to page zero, byte zero of memory.

The timing diagram in Figure 12 will help explain how the interrupt system works in the processor. The execution of the instruction labeled "A" has been proceeding before the start of this diagram. The last cycle of instruction "A" is shown. Notice that, as in all external operations, the OPREQ output eventually causes an OPACK input, which in turn allows OPREQ to be turned off. The arrows show this sequence of events. The last cycle of instruction "A" fetches the first byte of instruction "B" from Memory and inserts it into the Instruction Register.

Assume that instruction "B" is a two cycle, two byte instruction with no operand fetch (e.g., ADDI). Since the first byte has already been fetched by instruction "A", the first cycle of instruction "B" is used to fetch the second byte of instruction "B". Had instruction "B" not been interrupted, it would have fetched the first byte of the next sequential instruction during its second (last) cycle. The dotted lines indicate that operation.

Since instruction "B" is interrupted, however, the last cycle of "B" is used to insert the interrupt instruction (ZBSR) into the instruction register. Notice that the INTREQ input can arrive at any time. Instruction B is interrupted since INTREQ occurred prior to the last (2nd) cycle of execution.

Instead of being the next sequential instruction following "B", instruction "C" is the completion of the interrupt. The first cycle of "C" is used to fetch the second byte of the ZBSR instruction from the DBUS as provided by the interrupting device. This fact is indicated by the presence of the INTACK control signal. The INTREQ may then be removed. When the device responds with the requested byte, it uses a standard operation acknowledge procedure (OPACK) to so indicate to the processor. During the second cycle of instruction "C" the processor executes the ZBSR instruction, and fetches the first byte of instruction "D" which is located at the subroutine address.

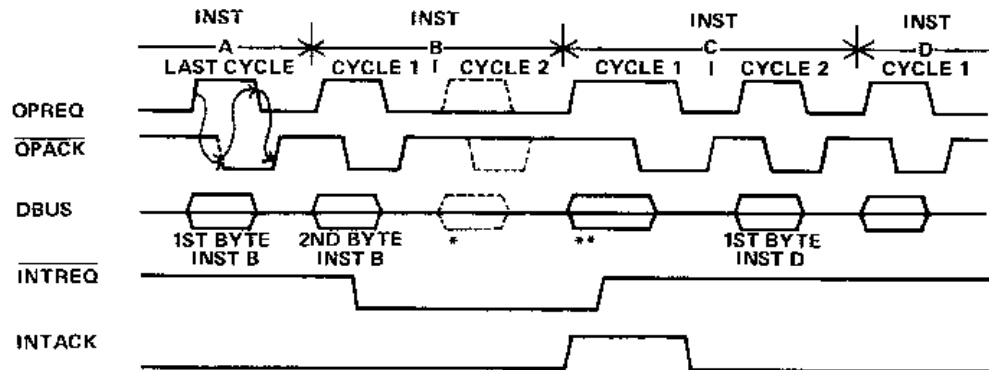

- * PROCESSOR INSERTS 1ST BYTE OF ZBSR INSTRUCTION. ADDRESS OF 1ST BYTE OF INSTC IS PUSHED INTO RETURN ADDRESS STACK.
- ** 2ND BYTE OF ZBSR (INTERRUPT VECTOR)

Figure 12. INTERRUPT TIMING

SUBROUTINE LINKAGE

The on-chip stack, along with the Branch-to-Subroutine and Return instructions provide the facility to transfer control to a subroutine. The subroutine can return control to the program that branched to it via a Return instruction.

The stack is eight levels deep which means that a routine may branch to a subroutine, which may branch to another subroutine, etc., eight times before any Return instructions are executed.

When designing a system that utilizes interrupts, it should be remembered that the processor jams a ZBSR into the IR and then executes it. This will cause an entry to be pushed into the on-chip stack like any other Branch-to-Subroutine instruction and may limit the stack depth available in certain programs.

When branching to a subroutine, the following sequence of events occurs:

1. The address in the IAR is used to fetch the Branch-to-Subroutine instruction and is then incremented in the Address Adder so that it points to the instruction following the subroutine branch.
2. The Stack Pointer is incremented by one so that it points to the next Return Address Stack location.
3. The contents of the IAR are stored in the stack at the location designated by the Stack Pointer.
4. The operand address contained in the Branch-to-Subroutine instruction (the address of the first instruction of the subroutine) is inserted into the IAR.

When returning from a subroutine, this sequence of events occurs:

1. The address in the IAR is used to fetch the return (RETC, RETE) instruction from memory.
2. When the return instruction is recognized by the processor, the contents of the stack entry pointed to by the Stack Pointer is placed into the IAR.
3. The Stack Pointer is decremented by one.
4. Instruction execution continues at the address now in the IAR.

CONDITION CODE USAGE

The two-bit register, called the Condition Code, is incorporated in the Program Status Word. It may be seen in the description of the 2650 instructions, that the Condition Code (CC) is specifically set by every instruction that causes data to be transferred into a general purpose register and it is also set by compare instructions.

The reason for this design feature is that after an instruction executes, the CC contains a modest amount of information about the byte of data which has just been manipulated. For example, a program loads register one with a byte of unknown data and the Condition Code setting indicates that the byte is positive, negative or zero. The negative indication implies that bit #7 is set to one.

Consequently, a data manipulation operation when followed by a conditional branch is often sufficient to determine desired information without resorting to a specific test, thus saving instructions and memory space.

In the following example, the Condition Code is used to test the parity of a byte of data which is stored at symbolic memory location CHAR.

```

EQ      EQU      0      THE EQUAL CONDITION CODE
CHAR    DATA    2      UNKNOWN DATA BYTE
WC      EQU      H'04'  THE WITH CARRY BIT
NEG     EQU      2      CC MASK
        CPSL     WC      CLEAR CARRY BIT
        LODL,R2   -8     SET UP COUNTER
        SUBZ     R0     CLEAR REG 0
        LODR,R1   CHAR   GET THE CHARACTER (cc is set)
LOOP    BCFR,NEG  G01    IF NOT SET, DON'T COUNT (cc is
                        tested)
        ADDL,R0   +1     COUNT THE BIT
G01     RRL,R1    MOVE BITS LEFT (cc is set)
        BIRR,R2   LOOP   LOOP TILL DONE

```

```

*      FINISHED,TEST IF REG 0 HAS A ONE IN LOW ORDER
*      IF BIT #0 = 1, ODD PARITY. IF BIT #0 = 0, THEN EVEN.

```

```

        TML,R0    H'01'
        BCTR,EQ   ODD
EVEN    HALT
ODD     HALT

```

START-UP PROCEDURE

The 2650 processor, having no internal start-up procedure must be started in an orderly fashion to assure that the internal control logic begins in a known state.

Assuming power is applied to the chip and the clock input is running, the easiest way to start is to apply a Reset signal for at least three clock periods. When the RESET signal is removed the processor will fetch the instruction at page 0, byte 0 and commence ordinary instruction execution.

To start processing at a specific address, a more complex start-up procedure may be employed. If an Interrupt signal is applied initially along with the Reset, processing will commence at the address provided by the interrupting device. Recall that the address provided may include a bit to specify indirect addressing and therefore the first instruction executed may be anywhere within addressable memory. The Reset and Interrupt signal may be applied simultaneously and when the Reset is removed, the processor will execute the usual interrupt signal sequence as described in INTERRUPT MECHANISM. There is an example of a start-up technique in the System Application Notes.

INSTRUCTIONS

ADDRESSING MODES

An addressing mode is a method the processor uses for developing argument addresses for machine instructions.

The 2650 processor can develop addresses in eight ways:

- Register addressing
- Immediate addressing
- Relative addressing
- Relative, indirect addressing
- Absolute addressing
- Absolute, indirect addressing
- Absolute, indexed addressing
- Absolute, indirect, indexed addressing

However, of these eight addressing modes, only four of them are basic. The others are variations due to indexing and indirection. The basic addressing mode of each instruction is indicated in parentheses in the first line of each detailed instruction description. The following text describes how effective addresses are developed by the processor.

REGISTER ADDRESSING

All register-to-register instructions are one byte in length. Instructions utilizing this addressing mode appear in this general format.

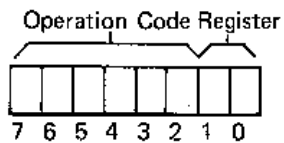

Since there are only two bits designated to specify a register, register zero always contains one of the operands while the other operand is in one of the three registers in the currently selected bank. Register zero may also be specified as the explicit operand giving instructions such as: `LODZ R0`.

In one byte register addressing instructions which have just one operand, any of the currently selected general purpose registers or register zero may be specified, e.g., `RRL,R0`.

IMMEDIATE ADDRESSING

All immediate addressing instructions are two bytes in length. The first byte contains the operation code and register designation, while the second byte contains data used as the argument during instruction execution.

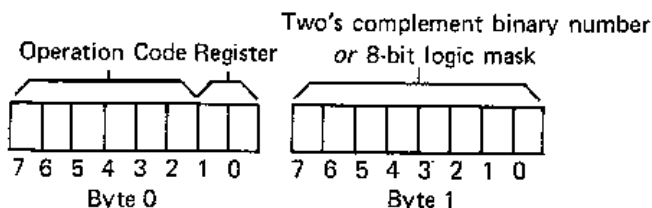

The second byte, the data byte, may contain a binary number or a logic mask depending on the particular instruction being executed. Any register may be designated in the first byte.

RELATIVE ADDRESSING

Relative addressing instructions are all two bytes in length and are memory reference instructions. One argument of the instruction is a register and the other argument is the contents of a memory location. The format of relative addressing instructions is:

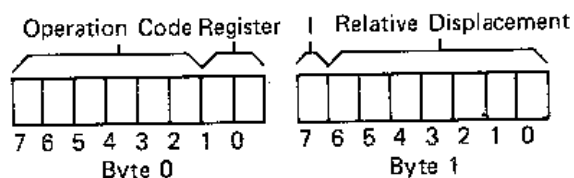

The first byte contains the operation code and register designation, while the second byte contains the relative address. Bits 0–6, byte 1, contain a 7-bit two's complement binary number which can range from -64 to +63. This number is used by the processor to calculate the effective address. The effective address is calculated by adding the address of the first byte following a relative addressing instruction to the relative displacement in the second byte of the instruction.

If bit 7, byte 1 is set to "1", the processor will enter an indirect addressing cycle, where the actual operand address will be accessed from the effective address location. See Indirect Addressing.

Two of the branch instructions (ZBSR, ZBRR) allow addressing relative to page zero, byte 0 of memory. In this case, values up to +63 reference the first 63 bytes of page zero and values up to -64 reference the last 64 bytes of page zero.

ABSOLUTE ADDRESSING FOR NON-BRANCH INSTRUCTIONS

Absolute addressing instructions are all three bytes in length and are memory reference instructions. One argument of the instruction is a register, designated in bits 1 and 0, byte 0; the other argument is the contents of a memory location. The format of absolute addressing instructions is:

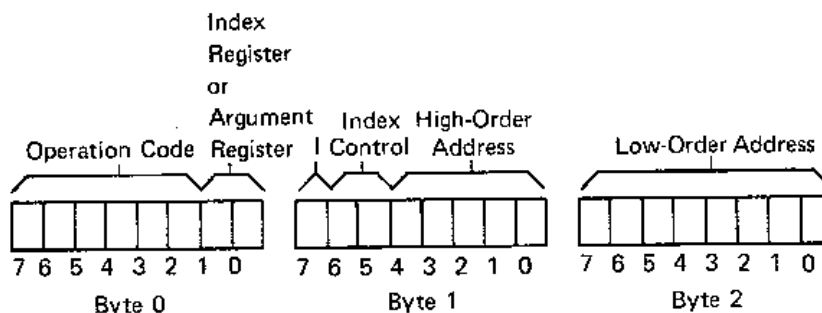

Bits 4–0, byte 1 and 7–0, byte 2 contain the absolute address and can address any byte within the same page that the instruction appears.

The index control bits, bits #6 and #5, byte 1 determine how the effective address will be calculated and possibly which register will be the argument during instruction execution. The index control bits have the following interpretation:

Index Control		Meaning
Bit 6	Bit 5	
0	0	Non-indexed address
0	1	Indexed with auto-increment
1	0	Indexed with auto-decrement
1	1	Indexed only

When the index control bits are 0 & 0, bits #1 and #0 in byte 0 contain the argument register designation and bits 0 to 4, byte 1 and bits 0 to 7, byte 2 contain the effective address. Indirect addressing may be specified by setting bit #7, byte 1 to a one.

When the index control bits are 1 & 1, bits #1 and #0 in byte 0 designate the index register and the argument register implicitly becomes register zero. The effective address is calculated by adding the contents of the index register (8-bit absolute integer) to the address field. If indirect addressing is specified, the indirect address is accessed and then the value in the index register is added to the indirect address. This is commonly called post indexing.

When the index control bits contain 0 & 1, the address is calculated by the processor exactly as when the control bits contain 1 & 1 *except* a binary 1 is added to the contents of the selected index register *before* the calculation of the effective address proceeds. Similarly, when the index control bits contain 1 & 0, a binary 1 is subtracted from the contents of the selected index register *before* the effective address is calculated.

ABSOLUTE ADDRESSING FOR BRANCH INSTRUCTIONS

The three byte, absolute addressing, branch instructions deviate slightly in format from ordinary absolute addressing instructions as shown below:

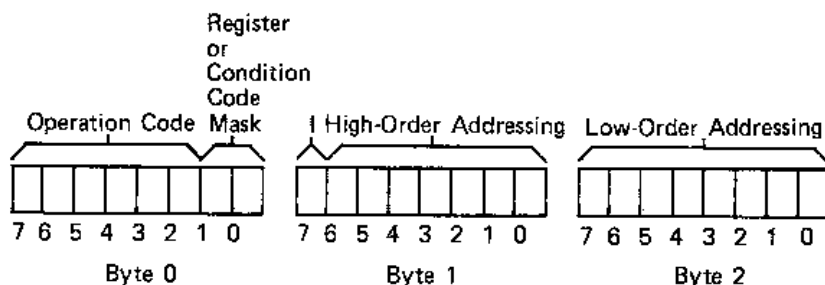

The notable difference is that bits 6 and 5, byte 1, are no longer interpreted as Index Control bits, but instead are interpreted as the high order bits of the address field. This means that there is no indexing allowed on most absolute addressing branch instructions, but indexed branches are possible through use of the BXA and BSXA instructions. The bits #6 and #5, byte 1, are used to set the current page register, thus enabling programs to directly transfer control to another page.

See the MEMORY ORGANIZATION, BXA and BSXA instructions, and INDIRECT ADDRESSING.

INDIRECT ADDRESSING

Indirect addressing means that the argument address of an instruction is not specified by the instruction itself, but rather the argument address will be found in the two bytes pointed to by the address field or relative address field, of absolute or relative addressing instructions. In the case of absolute addressing, the value of the index register is added to the indirect address *not* to the value in the address field of the instruction. In both cases, the processor will enter the indirect addressing state when the bit designated "I" is set to one. Entering the indirect addressing sequence adds two cycles (6 clock periods) to the execution time of an instruction.

Indirect addresses are 15-bit addresses stored right justified in two contiguous bytes of memory. As such, an indirect address may specify any location in addressable memory (0–32,767). The high order bit of the two byte indirect address is not used by the processor.

Only single level indirect addressing is implemented. The following examples demonstrate indirect addressing.

Example 1.

	0 0 0 0 1 1 1 0	1 0 0 0 0 0 0 0	0 1 0 1 0 0 0 1	LODA,R2 *H'51'
Address	10 ₁₆	11 ₁₆	12 ₁₆	
		0 0 0 0 0 0 0 1	0 0 1 0 1 0 0 0	ACON H'128'
Address		51 ₁₆	52 ₁₆	
		0 1 1 0 0 1 1 1		DATA H'67'
Address		128 ₁₆		

The LODA instruction in memory locations 10, 11, and 12 specifies indirect addressing (bit 7, byte 1, is set). Therefore, when the instruction is executed, the processor takes the address field value, H'51', and uses it to access the two byte indirect address at 51 and 52. Then using the contents of 51 and 52 as the effective address, the data byte containing H'67' is loaded into register 2.

Example 2.

	0 0 0 0 1 0 1 0	1 0 0 0 0 1 0 1	LODR,R2 *H'17'	
Address	10 ₁₆	11 ₁₆		
		0 0 0 0 0 0 0 1	0 0 1 0 1 0 0 0	ACON H'128'
Address		17 ₁₆	18 ₁₆	
		0 1 1 0 0 1 1 1		DATA H'67'
Address		128 ₁₆		

In a fashion similar to the previous example, the relative address is used to access the indirect address which points to the data byte. When the LODR instruction is executed, the data byte contents, H'67', will be loaded into register 2.

INSTRUCTIONS FORMAT EXCEPTIONS

There are several instructions which are detected by decoding the entire 8 bits of the first byte of the instruction. These instructions are unique and may be noticed in the instruction descriptions. Examples are: HALT, CPSU, CPSL.

Of this type of instruction, two operation codes were taken from otherwise complete sets thus eliminating certain possible operations. The cases are as follows:

(NOT OKAY)	STRZ	0	} Storing register zero into register zero is not implemented, the operation code is used for NOP (no operation).
(OKAY)	NOP		
(NOT OKAY)	ANDZ	0	} AND of register zero with register zero is not implemented, the operation code is used for HALT.
(OKAY)	HALT		

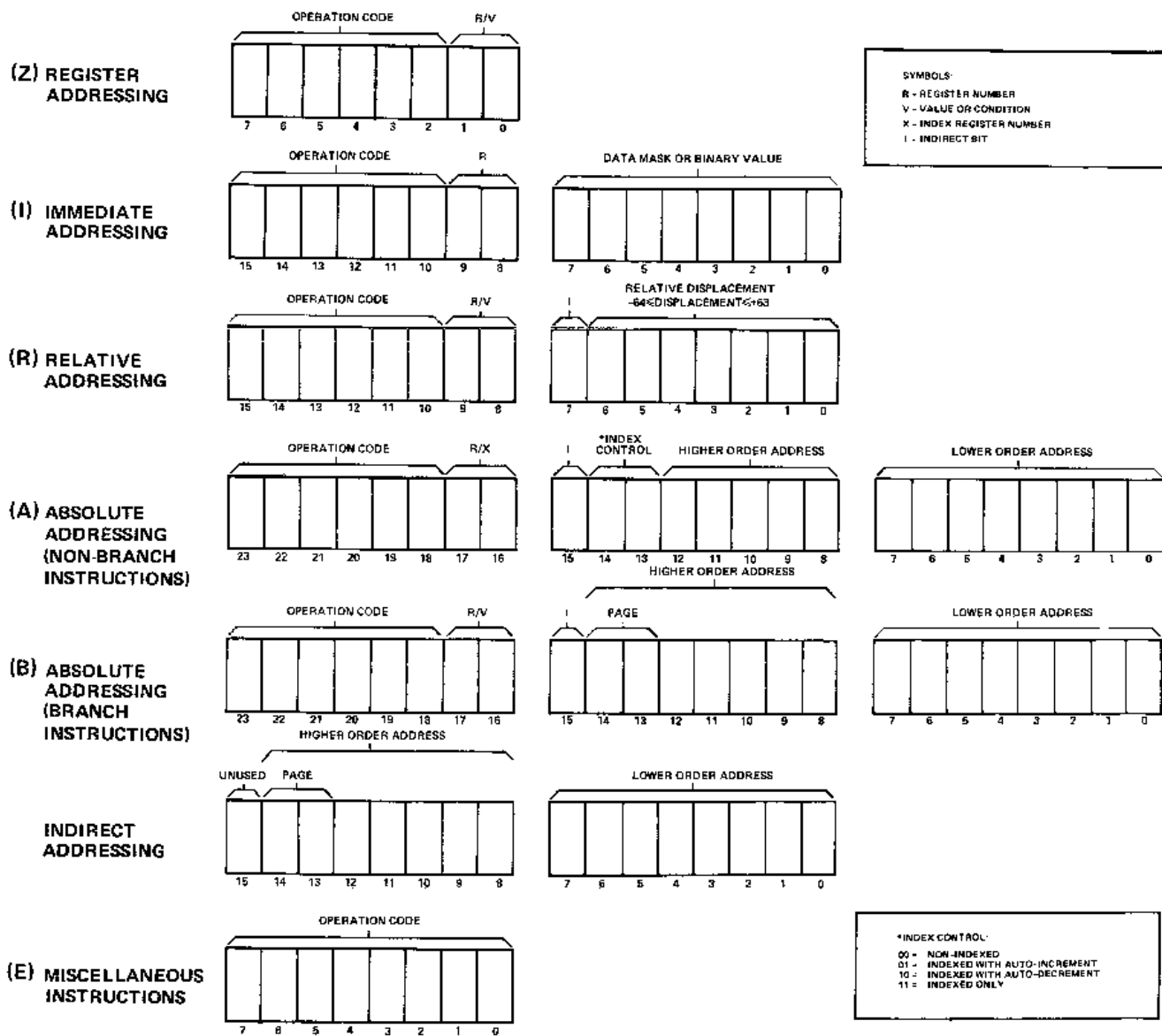

Figure 13. INSTRUCTION FORMATS

DETAILED PROCESSOR INSTRUCTIONS

LOAD REGISTER ZERO

(Register Addressing)

Mnemonic LODZ r

Binary Coding

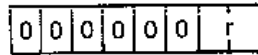

7 6 5 4 3 2 1 0

Execution Time 2 cycles (6 clock periods)

Description

This one-byte instruction transfers the contents of the specified register, r, into register zero. The previous contents of register zero are lost. The contents of register r remain unchanged.

When the specified register, r, equals 0, the operation code is changed to 60_{16} by the assembler. The instruction, 00000000, yields indeterminate results.

Processor Registers Affected

CC

Condition Code Setting

Register Zero	CC1	CC0
Positive	0	1
Zero	0	0
Negative	1	0

LOAD IMMEDIATE

(Immediate Addressing)

Mnemonic LODI,r v

Binary Coding



7 6 5 4 3 2 1 0 7 6 5 4 3 2 1 0

Execution Time 2 cycles (6 clock periods)

Description

This two-byte instruction transfers the second byte of the instruction, v, into the specified register, r. The previous contents of r are lost.

Processor Registers Affected

CC

Condition Code Setting

Register r	CC1	CC0
Positive	0	1
Zero	0	0
Negative	1	0

LOAD RELATIVE

(Relative Addressing)

Mnemonic LODR,r (*)a

Binary Coding

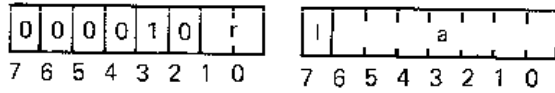

Execution Time 3 cycles (9 clock periods)

Description

This two-byte instruction transfers a byte of data from memory into the specified register, r. The data byte is found at the effective address formed by the addition of the a field and the address of the byte following this instruction. The previous contents of register r are lost. Indirect addressing may be specified.

Processor Registers Affected

CC

Condition Code Setting

Register r	CC1	CC0
Positive	0	1
Zero	0	0
Negative	1	0

LOAD ABSOLUTE

(Absolute Addressing)

Mnemonic LODA,r (*)a,(X)

Binary Coding

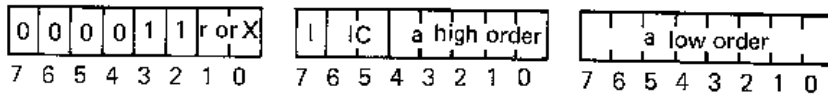

Execution Time 4 cycles (12 clock periods)

Description

This three-byte instruction transfers a byte of data from memory into the specified register, r. The data byte is found at the effective address. If indexing is specified, bits 1 and 0, byte 0, indicate the index register and the destination of the operation implicitly becomes register zero. The previous contents of register r are lost.

Indirect addressing and/or indexing may be specified.

Processor Registers Affected

CC

Condition Code Setting

Register r	CC1	CC0
Positive	0	1
Zero	0	0
Negative	1	0

STORE REGISTER ZERO

(Register Addressing)

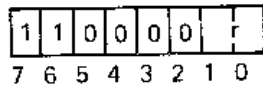
Mnemonic STRZ r**Binary Code****Execution Time** 2 cycles (6 clock periods)**Description**

This one-byte instruction transfers the contents of register zero into the specified register r. The previous contents of register r are lost. The contents of register zero remain unchanged.

Note: Register r may not be specified as zero. This operation code, '11000000', is reserved for NOP.

Processor Registers Affected	CC
Condition Code Setting	Register r CC1 CC0
	Positive 0 1
	Zero 0 0
	Negative 1 0

STORE RELATIVE

(Relative Addressing)

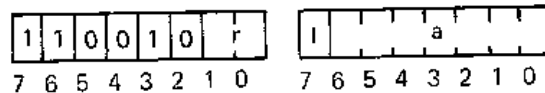
Mnemonic STRR,r (*a)**Binary Code****Execution Time** 3 cycles (9 clock periods)**Description**

This two-byte instruction transfers a byte of data from the specified register, r, into the byte of memory pointed to by the effective address. The contents of register r remain unchanged and the contents of the memory byte are replaced.

Indirect addressing may be specified.

Processor Registers Affected	None
Condition Code Setting	N/A

STORE ABSOLUTE(Absolute Addressing)

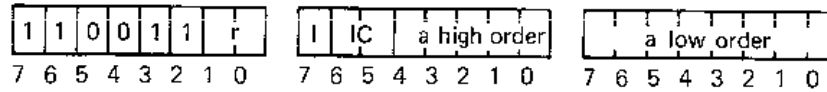
Mnemonic STRA,r (*)a(X)**Binary Code****Execution Time** 4 cycles (12 clock periods)**Description**

This three-byte instruction transfers a byte of data from the specified register, r, into the byte of memory pointed to by the effective address. The contents of register r remain unchanged and the contents of the memory byte are replaced.

Indirect addressing and/or indexing may be specified. If indexing is specified, bits 1 and 0, byte 0, indicate the index register and the destination of the operation implicitly becomes register zero.

Processor Registers Affected None**Condition Code Setting** N/A

ADD TO REGISTER ZERO(Register Addressing)

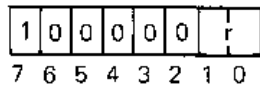
Mnemonic ADDZ r**Binary Code****Execution Time** 2 cycles (6 clock periods)**Description**

This one-byte instruction causes the contents of the specified register, r, and the contents of register zero to be added together in a true binary adder. The 8-bit sum of the addition replaces the contents of register zero. The contents of register r remain unchanged.

Note: Add with Carry may be effected. See Carry bit.

Processor Registers Affected C, CC, IDC, OVF

Condition Code Setting	Register Zero	CC1	CC0
	Positive	0	1
Zero	0	0	
Negative	1	0	

ADD IMMEDIATE

(Immediate Addressing)

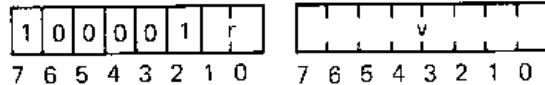
Mnemonic ADDI,r v**Binary Coding****Execution Time** 2 cycles (6 clock periods)**Description**

This two-byte instruction causes the contents of register r and the contents of the second byte of this instruction to be added together in a true binary adder. The eight-bit sum replaces the contents of register r.

Note: Add with Carry may be effected. See Carry bit.

Processor Registers Affected	C, CC, IDC, OVF		
Condition Code Setting	Register r	CC1	CC0
	Positive	0	1
	Zero	0	0
	Negative	1	0

ADD RELATIVE

(Relative Addressing)

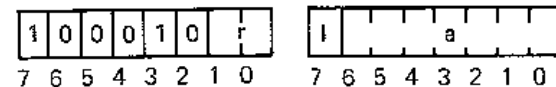
Mnemonic ADDR,r (+)a**Binary Coding****Execution Time** 3 cycles (9 clock periods)**Description**

This two-byte instruction causes the contents of register r and the contents of the byte of memory pointed to by the effective address to be added together in a true binary adder. The eight-bit sum replaces the contents of register r.

Indirect addressing may be specified.

Note: Add with Carry may be effected. See Carry bit.

Processor Registers Affected	C, CC, IDC, OVF		
Condition Code Setting	Register r	CC1	CC0
	Positive	0	1
	Zero	0	0
	Negative	1	0

ADD ABSOLUTE

(Absolute Addressing)

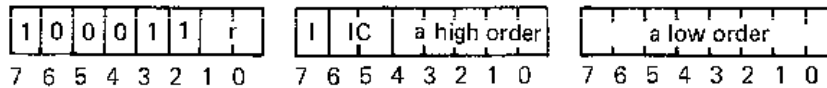
Mnemonic ADDA,r (*)a(X)**Binary Coding****Execution Time** 4 cycles (12 clock periods)**Description**

This three-byte instruction causes the contents of register r and the contents of the byte of memory pointed to by the effective address to be added together in a true binary adder. The eight-bit sum replaces the contents of register r.

Indirect addressing and/or indexing may be specified. If indexing is specified, bits 1 and 0, byte 0, indicate the index register and the destination of the operation implicitly becomes register zero.

Note: Add with Carry may be effected. See Carry bit.

Processor Registers Affected	C, CC, IDC, OVF		
Condition Code Setting	Register r	CC1	CC0
	Positive	0	1
	Zero	0	0
	Negative	1	0

SUBTRACT FROM REGISTER ZERO

(Register Addressing)

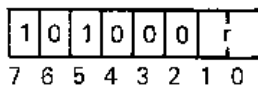
Mnemonic SUBZ r**Binary Coding****Execution Time** 2 cycles (6 clock periods)**Description**

This one-byte instruction causes the contents of the specified register r to be subtracted from the contents of register zero. The result of the subtraction replaces the contents of register zero.

The subtraction is performed by taking the binary two's complement of the contents of register r and adding that result to the contents of register zero. The contents of register r remain unchanged.

Note: Subtract with Borrow may be effected. See Carry bit.

Processor Registers Affected	C, CC, IDC, OVF		
Condition Code Setting	Register Zero	CC1	CC0
	Positive	0	1
	Zero	0	0
	Negative	1	0

SUBTRACT IMMEDIATE

(Immediate Addressing)

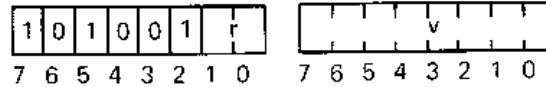
Mnemonic SUBI,*r* *v***Binary Code****Execution Time** 2 cycles (6 clock periods)**Description**

This two-byte instruction causes the contents of the second byte of this instruction to be subtracted from the contents of register *r*. The result of the subtraction replaces the contents of register *r*.

The subtraction is performed by taking the binary two's complement of the contents of the second instruction byte and adding that result to the contents of register *r*.

Note: Subtract with Borrow may be effected. See Carry bit.

Processor Registers Affected	C, CC, IDC, OVF		
Condition Code Setting	Register <i>r</i>	CC1	CC0
	Positive	0	1
	Zero	0	0
	Negative	1	0

SUBTRACT RELATIVE

(Relative Addressing)

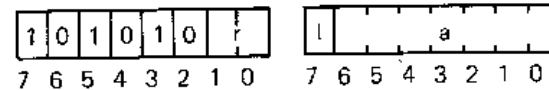
Mnemonic SUBR,*r* (**a*)**Binary Code****Execution Time** 3 cycles (9 clock periods)**Description**

This two-byte instruction causes the contents of the byte of memory pointed to by the effective address to be subtracted from the contents of register *r*. The result of the subtraction replaces the contents of register *r*.

The subtraction is performed by taking the binary two's complement of the contents of the byte of memory and adding that result to the contents of register *r*.

Indirect addressing may be specified.

Note: Subtract with Borrow may be effected. See Carry bit.

Processor Registers Affected	C, CC, IDC, OVF		
Condition Code Setting	Register <i>r</i>	CC1	CC0
	Positive	0	1
	Zero	0	0
	Negative	1	0

SUBTRACT ABSOLUTE(Absolute Addressing)

Mnemonic SUBA,r (*)a(X)

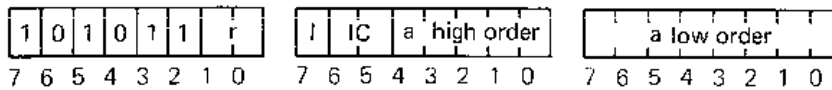
Binary Code**Execution Time** 4 cycles (12 clock periods)**Description**

This three-byte instruction causes the contents of the byte of memory pointed to by the effective address to be subtracted from the contents of register r. The result of the subtraction replaces the contents of register r.

The subtraction is performed by taking the binary two's complement of the contents of the memory byte and adding that result to the contents of register r.

Indirect addressing and/or indexing may be specified. If indexing is specified, bits 1 and 0, byte 0, indicate the index register and the destination of the operation implicitly becomes register zero.

Note: Subtract with Borrow may be effected. See Carry bit.

Processor Registers Affected	C, CC, IDC, OVF
Condition Code Setting	Register r CC1 CC0
	Positive 0 1
	Zero 0 0
	Negative 1 0

AND TO REGISTER ZERO(Register Addressing)

Mnemonic ANDZ r

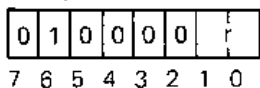
Binary Code**Execution Time** 2 cycles (6 clock periods)**Description**

This one-byte instruction causes the contents of the specified register, r, to be logically ANDed with the contents of register zero. The result of the operation replaces the contents of register zero. The contents of register r remain unchanged.

The AND operation treats each bit of the argument bytes as in the truth table below:

Bit (0-7)	Bit (0-7)	AND Result
0	0	0
0	1	0
1	1	1
1	0	0

Note: Register r may not be specified as zero. This operation code, '01000000', is reserved for HALT.

Processor Registers Affected	CC
Condition Code Setting	Register Zero CC1 CC0
	Positive 0 1
	Zero 0 0
	Negative 1 0

AND IMMEDIATE

(Immediate Addressing)

Mnemonic ANDI,r v

Binary Code



Execution Time 2 cycles (6 clock periods)

Description

This two-byte instruction causes the contents of the specified register r to be logically ANDed with the contents of the second byte of this instruction. The result of this operation replaces the contents of register r.

The AND operation treats each bit of the argument bytes as in the truth table below:

Bit (0-7)	Bit (0-7)	AND Result
0	0	0
0	1	0
1	1	1
1	0	0

Processor Registers Affected

CC

Condition Code Setting

Register Zero	CC1	CC0
Positive	0	1
Zero	0	0
Negative	1	0

AND RELATIVE

(Relative Addressing)

Mnemonic ANDR,r (*)a

Binary Code

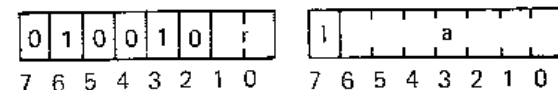

Execution Time 3 cycles (9 clock periods)

Description

This two-byte instruction causes the contents of the specified register r to be logically ANDed with the contents of the memory byte pointed to by the effective address. The result of this operation replaces the contents of register r.

The AND operation treats each bit of the argument bytes as in the truth table below:

Bit (0-7)	Bit (0-7)	AND Result
0	0	0
0	1	0
1	1	1
1	0	0

Processor Registers Affected

CC

Condition Code Setting

Register Zero	CC1	CC0
Positive	0	1
Zero	0	0
Negative	1	0

AND ABSOLUTE(Absolute Addressing)

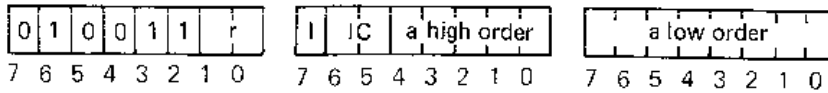
Mnemonic **ANDA,r** **(*a,X)****Binary Code****Execution Time** 4 cycles (12 clock periods)**Description**

This three-byte instruction causes the contents of Register r to be logically ANDed with the contents of memory byte pointed to by the effective address. The result of the operation replaces the contents of register r.

The AND operation treats each bit of the argument bytes as in the truth table below:

Bit (0-7)	Bit (0-7)	AND Result
0	0	0
0	1	0
1	1	1
1	0	0

Indirect addressing and/or indexing may be specified. If indexing is specified, bits 1 and 0, byte 0, indicate the index register and the destination of the operation implicitly becomes register zero.

Processor Registers Affected

CC

Condition Code Setting

Register Zero	CC1	CC0
Positive	0	1
Zero	0	0
Negative	1	0

INCLUSIVE OR TO REGISTER ZERO(Register Addressing)

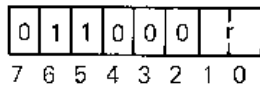
Mnemonic **IORZ** **r****Binary Code****Execution Time** 2 cycles (6 clock periods)**Description**

This one-byte instruction causes the contents of the specified register, r, to be logically Inclusive ORed with the contents of register zero. The result of this operation replaces the contents of register zero. The contents of register r remain unchanged.

The Inclusive OR operation treats each bit of the argument bytes as in the truth table below:

Bit (0-7)	Bit (0-7)	Inclusive OR Result
0	0	0
0	1	1
1	1	1
1	0	1

Processor Registers Affected

CC

Condition Code Setting

Register Zero	CC1	CC0
Positive	0	1
Zero	0	0
Negative	1	0

INCLUSIVE OR IMMEDIATE

(Immediate Addressing)

Mnemonic IORI,r v

Binary Code

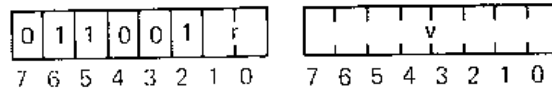

Execution Time 2 cycles (6 clock periods)

Description

This two-byte instruction causes the contents of the specified register *r* to be logically Inclusive ORed with the contents of the second byte of this instruction. The result of this operation replaces the contents of register *r*.

The Inclusive OR operation treats each bit of the argument bytes as in the truth table below:

Bit (0-7)	Bit (0-7)	Inclusive OR Result
0	0	0
0	1	1
1	1	1
1	0	1

Processor Registers Affected

CC

Condition Code Setting

Register <i>r</i>	CC1	CC0
Positive	0	1
Zero	0	0
Negative	1	0

INCLUSIVE OR RELATIVE

(Relative Addressing)

Mnemonic IORR,r (**a*)

Binary Code

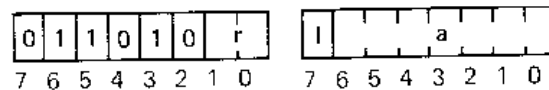

Execution Time 3 cycles (9 clock periods)

Description

This two-byte instruction causes the contents of the specified register *r* to be logically Inclusive ORed with the contents of the memory byte pointed to by the effective address. The result of this operation replaces the previous contents of register *r*.

Indirect addressing may be specified.

The Inclusive OR operation treats each bit of the argument byte as in the truth table below:

Bit (0-7)	Bit (0-7)	Inclusive OR Result
0	0	0
0	1	1
1	1	1
1	0	1

Processor Registers Affected

CC

Condition Code Setting

Register <i>r</i>	CC1	CC0
Positive	0	1
Zero	0	0
Negative	1	0

INCLUSIVE OR ABSOLUTE

(Absolute Addressing)

Mnemonic IORA,r (*)a(X)

Binary Code

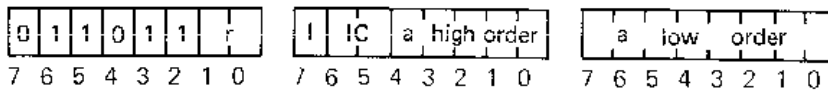

Execution Time 4 cycles (12 clock periods)

Description

This three-byte instruction causes the contents of register r to be logically Inclusive ORed with the contents of the memory byte pointed to by the effective address. The result of the operation replaces the previous contents of register r.

Indirect addressing and/or indexing may be specified. If indexing is specified, bits 1 and 0, byte 0, indicate the index register and the destination of the operation implicitly becomes register zero.

The Inclusive OR operation treats each bit of the argument bytes as in the truth table below:

Bit (0-7)	Bit (0-7)	Inclusive OR Result
0	0	0
0	1	1
1	1	1
1	0	1

Processor Registers Affected

CC

Condition Code Setting

Register Zero	CC1	CC0
Positive	0	1
Zero	0	0
Negative	1	0

EXCLUSIVE OR TO REGISTER ZERO

(Register Addressing)

Mnemonic EORZ r

Binary Code

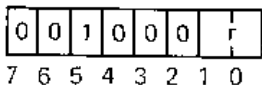

Execution Time 2 cycles (6 clock periods)

Description

This one-byte instruction causes the contents of the specified register r to be logically Exclusive ORed with the contents of register zero. The result of this operation replaces the contents of register zero. The contents of register r remain unchanged.

The Exclusive OR operation treats each bit of the argument bytes as in the truth table below:

Bit (0-7)	Bit (0-7)	Exclusive OR Result
0	0	0
0	1	1
1	1	0
1	0	1

Processor Registers Affected

CC

Condition Code Setting

Register Zero	CC1	CC0
Positive	0	1
Zero	0	0
Negative	1	0

EXCLUSIVE OR IMMEDIATE(Immediate Addressing)

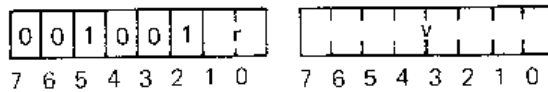
Mnemonic EORI,r v**Binary Code****Execution Time** 2 cycles (6 clock periods)**Description**

This two-byte instruction causes the contents of the specified register r to be logically Exclusive ORed with the contents of the second byte of this instruction. The result of this operation replaces the previous contents of register r.

The Exclusive OR operation treats each bit of the argument bytes as in the truth table below:

Bit (0-7)	Bit (0-7)	Exclusive OR Result
0	0	0
0	1	1
1	1	0
1	0	1

Processor Registers Affected

CC

Condition Code Setting

Register r	CC1	CC0
Positive	0	1
Zero	0	0
Negative	1	0

EXCLUSIVE OR RELATIVE(Relative Addressing)

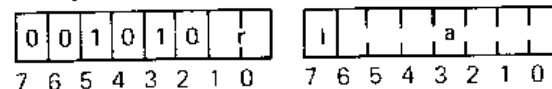
Mnemonic EORR,r (*a)**Binary Code****Execution Time** 3 cycles (9 clock periods)**Description**

This two-byte instruction causes the contents of the specified register r to be logically Exclusive ORed with the contents of the memory byte pointed to by the effective address. The result of this operation replaces the previous contents of register r.

Indirect addressing may be specified.

The Exclusive OR operation treats each bit of the argument bytes as in the truth table below:

Bit (0-7)	Bit (0-7)	Exclusive OR Result
0	0	0
0	1	1
1	1	0
1	0	1

Processor Registers Affected

CC

Condition Code Setting

Register r	CC1	CC0
Positive	0	1
Zero	0	0
Negative	1	0

EXCLUSIVE OR ABSOLUTE

(Absolute Addressing)

Mnemonic EORA,r (*a(X))

Binary Code

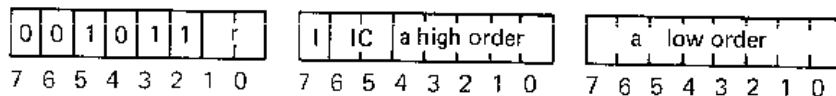

Execution Time 4 cycles (12 clock periods)

Description

This three-byte instruction causes the contents of register *r* to be Exclusive ORed with the contents of the memory byte pointed to by the effective address. The result of the operation replaces the previous contents of register *r*.

Indirect addressing and/or indexing may be specified. If indexing is specified, bits 1 and 0, byte 0, indicate the index register and the destination of the operation implicitly becomes register zero.

The Exclusive OR operation treats each bit of the argument bytes as in the truth table below:

Bit (0-7)	Bit (0-7)	Exclusive OR Result
0	0	0
0	1	1
1	1	0
1	0	1

Processor Registers Affected

CC

Condition Code Setting

Register <i>r</i>	CC1	CC0
Positive	0	1
Zero	0	0
Negative	1	0

COMPARE TO REGISTER ZERO

(Register Addressing)

Mnemonic COMZ *r*

Binary Code

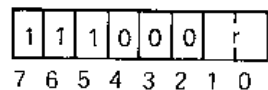

Execution Time 2 cycles (6 clock periods)

Description

This one-byte instruction causes the contents of the specified register *r* to be compared to the contents of register zero. The comparison will be performed in either "arithmetic" or "logical" mode depending on the setting of the COM bit in the Program Status Word.

When COM=1 (logical mode) the values will be interpreted as 8-bit positive binary numbers; when COM=0, the values will be interpreted as 8-bit two's complement numbers.

The execution of this instruction *only* causes the Condition Code to be set as in the following table.

Processor Registers Affected

CC

Condition Code Setting

	CC1	CC0
Register zero greater than Register <i>r</i>	0	1
Register zero equal to Register <i>r</i>	0	0
Register zero less than Register <i>r</i>	1	0

COMPARE IMMEDIATE(Immediate Addressing)

Mnemonic COMI,r v

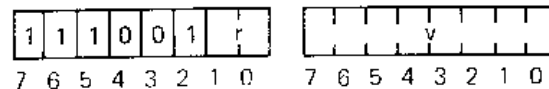
Binary Code**Execution Time** 2 cycles (6 clock periods)**Description**

This two-byte instruction causes the contents of the specified register r to be compared to the contents of the second byte of this instruction. The comparison will be performed in either the “arithmetic” or “logical” mode depending on the setting of the COM bit in the Program Status Word.

When COM=1 (logical mode), the values will be treated as 8-bit positive binary numbers; when COM=0, the values will be treated as 8-bit two’s complement numbers.

The execution of this instruction *only* causes the Condition Code to be set as in the following table.

Processor Registers Affected	CC	CC1	CC0
Condition Code Setting			
Register r greater than v		0	1
Register r equal to v		0	0
Register r less than v		1	0

COMPARE RELATIVE(Relative Addressing)

Mnemonic COMR,r (*a)

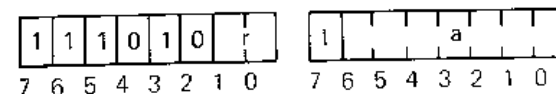
Binary Code**Execution Time** 3 cycles (9 clock periods)**Description**

This two-byte instruction causes the contents of the specified register r to be compared to the contents of the memory byte pointed to by the effective address. The comparison will be performed in either the “arithmetic” or “logical” mode depending upon the setting of the COM bit in the Program Status Word.

When COM=1 (logical mode), the values will be treated as 8-bit positive binary numbers; when COM=0, the values will be treated as 8-bit, two’s complement numbers.

The execution of this instruction *only* causes the Condition Code to be set as in the following table.

Processor Registers Affected	CC	CC1	CC0
Condition Code Setting			
Register r greater than memory byte		0	1
Register r equal to memory byte		0	0
Register r less than memory byte		1	0

COMPARE ABSOLUTE

(Absolute Addressing)

Mnemonic COMA,r (+)a(X)
Binary Code

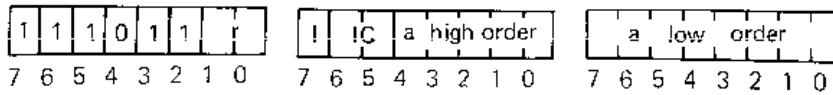

Execution Time 4 cycles (12 clock periods)

Description

This three-byte instruction causes the contents of register r to be compared to the contents of the memory byte pointed to by the effective address. The comparison will be performed in either the "arithmetic" or "logical" mode depending on the setting of the COM bit in the Program Status Word.

Where COM=1 (logical mode), the values will be treated as 8-bit, positive binary numbers; when COM=0 (arithmetic mode), the values will be treated as 8-bit, two's complement numbers.

Indirect addressing and/or indexing may be specified. If indexing is specified, bits 1 and 0, byte 0, indicate the index register and the destination of the operation implicitly becomes register zero.

The execution of this instruction *only* causes the Condition Code to be set as in the following table.

Processor Registers Affected	CC	CC1	CC0
Condition Code Setting			
Register r greater than memory byte		0	1
Register r equal to memory byte		0	0
Register r less than memory byte		1	0

ROTATE REGISTER LEFT

(Register Addressing)

Mnemonic RRL,r
Binary Code

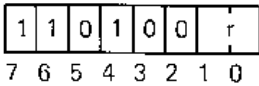

Execution Time 2 cycles (6 clock periods)

Description

This one-byte instruction causes the contents of the specified register r to be shifted left one bit. If the WC bit in the Program Status Word is set to zero, bit #7 of register r flows into bit #0; if WC=1, then bit #7 flows into the Carry bit and the Carry bit flows into bit #0.

Register bit #4 flows into the IDC if WC=1.

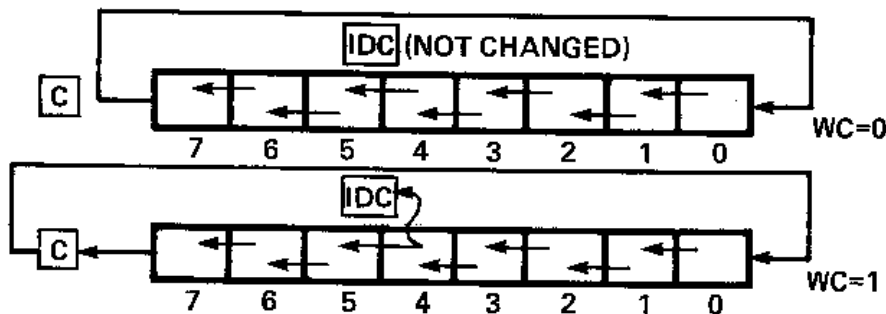

Note: Whenever a rotate causes bit #7 of the specified register to change polarity, the OVF bit is set in the PSL.

Processor Registers Affected	C, CC, IDC, OVF		
Condition Code Setting	Register r	CC1	CC0
Positive		0	1
Zero		0	0
Negative		1	0

ROTATE REGISTER RIGHT

(Register Addressing)

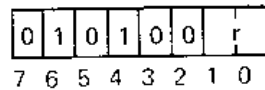
Mnemonic RRR,r**Binary Code****Execution Time** 2 cycles (6 clock periods)**Description**

This one-byte instruction causes the contents of the specified register r to be shifted right one bit. If the WC bit in the Program Status Word is set to zero, bit #0 of the register r flows into bit #7; if WC=1, then bit #0 of the register r flows into the Carry bit and the Carry bit flows into bit #7.

Register bit #6 flows into the IDC if WC=1.

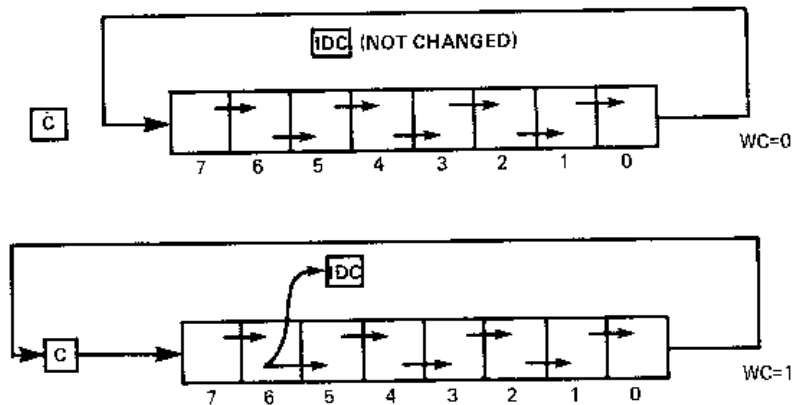

Note: Whenever a rotate causes bit #7 of the specified register to change polarity, the OVF bit is set in the PSL.

Processor Registers Affected	C, CC, IDC, OVF		
Condition Code Setting	Register r	CC1	CC0
	Positive	0	1
	Zero	0	0
	Negative	1	0

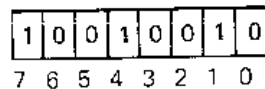
LOAD PROGRAM STATUS, UPPER**Mnemonic** LPSU**Binary Code****Execution Time** 2 cycles (6 clock periods)**Description**

This one-byte instruction causes the current contents of the Upper Program Status Byte to be replaced with the contents of register zero.

See Program Status Word description for bit assignments. Bits #4 and #3 of the PSU are unassigned and will always be regarded as containing zeroes.

Processor Registers Affected	F, II, SP
Condition Code Setting	N/A

LOAD PROGRAM STATUS, LOWER

Mnemonic LPSL

Binary Code

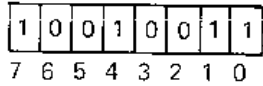

Execution Time 2 cycles (6 clock periods)

Description

This one-byte instruction causes the current contents of the Lower Program Status Byte to be replaced with the contents of register zero.

See Program Status Word description for bit assignments.

Processor Registers Affected CC, IDC, RS, WC, OVF, COM, C

Condition Code Setting

The CC will take on the value in bits #7 and #6 of register zero.

STORE PROGRAM STATUS, UPPER

Mnemonic SPSU

Binary Code

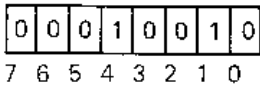

Execution Time 2 cycles (6 clock periods)

Description

This one-byte instruction causes the contents of the Upper Program Status Byte to be transferred into register zero.

See Program Status Word description for bit assignments. Bits #4 and #3 which are unassigned will always be stored as zeroes.

Processor Registers Affected CC

Condition Code Setting	Register Zero	CC1	CC0
Positive	0	0	1
Zero	0	0	0
Negative	1	1	0

STORE PROGRAM STATUS, LOWER

Mnemonic SPSL

Binary Code

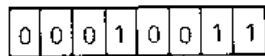

7 6 5 4 3 2 1 0

Execution Time 2 cycles (6 clock periods)

Description

This one-byte instruction causes the contents of the Lower Program Status Byte to be transferred into register zero.

See Program Status Word description for bit assignments.

Processor Registers Affected	CC		
Condition Code Setting	Register Zero	CC1	CC0
	Positive	0	1
	Zero	0	0
	Negative	1	0

PRESET PROGRAM STATUS UPPER, SELECTIVE (Immediate Addressing)

Mnemonic PPSU v

Binary Code

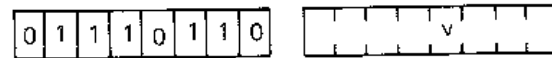

7 6 5 4 3 2 1 0 7 6 5 4 3 2 1 0

Execution Time 3 cycles (9 clock periods)

Description

This two-byte instruction causes individual bits in the Upper Program Status Byte to be selectively set to binary one. When this instruction is executed, each bit in the v field of the second byte of this instruction is tested for the presence of a one and if a particular bit in the v field contains a one, the corresponding bit in the status byte is set to binary one. Any bits in the status byte which are not selected are not modified.

Processor Registers Affected	F, II, SP
Condition Code Setting	N/A

PRESET PROGRAM STATUS LOWER, SELECTIVE (Immediate Addressing)

Mnemonic PPSL v

Binary Code

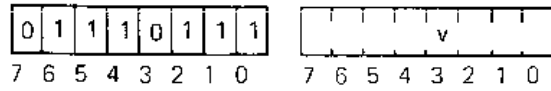

Execution Time 3 cycles (9 clock periods)

Description

This two-byte instruction causes individual bits in the Lower Program Status Byte to be selectively set to binary one. When this instruction is executed, each bit in the v field of the second byte of this instruction is tested for the presence of a one and if a particular bit in the v field contains a one, the corresponding bit in the status byte is set to binary one. Any bits in the status byte which are not selected are not modified.

Processor Registers Affected CC, IDC, RS, WC, OVF, COM, C

Condition Code Setting

The CC bits may be set by the execution of this instruction.

CLEAR PROGRAM STATUS UPPER, SELECTIVE (Immediate Addressing)

Mnemonic CPSU v

Binary Code

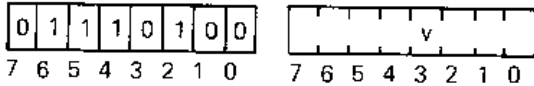

Execution Time 3 cycles (9 clock periods)

Description

This two-byte instruction causes individual bits in the Upper Program Status Byte to be selectively cleared. When this instruction is executed, each bit in the v field of the second byte of this instruction is tested for the presence of a one and if a particular bit in the v field contains a one, the corresponding bit in the status byte is cleared to zero. Any bits in the status byte which are not selected are not modified.

Processor Registers Affected F, II, SP

Condition Code Setting N/A

CLEAR PROGRAM STATUS LOWER, SELECTIVE (Immediate Addressing)

Mnemonic CPSL v

Binary Code

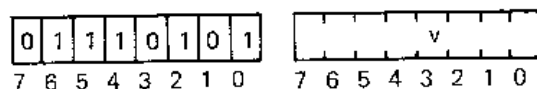

Execution Time 3 cycles (9 clock periods)

Description

This two-byte instruction causes individual bits in the Lower Program Status Byte to be selectively cleared. When this instruction is executed, each bit in the v field of the second byte of this instruction is tested for the presence of a one and if a particular bit in the v field contains a one, the corresponding bit in the status byte is cleared to zero. Any bits in the status byte which are not selected are not modified.

Processor Registers Affected CC, IDC, RS, WC, OVF, COM, C

Condition Code Setting

The CC bits may be cleared by the execution of this instruction.

TEST PROGRAM STATUS UPPER, SELECTIVE (Immediate Addressing)

Mnemonic TPSU v

Binary Code

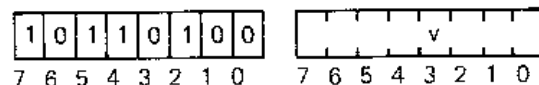

Execution Time 3 cycles (9 clock periods)

Description

This two-byte instruction tests individual bits in the Upper Program Status Byte to determine if they are set to binary one. When this instruction is executed, each bit in the v field of this instruction is tested for the presence of a one, and if a particular bit in the v field contains a one, the corresponding bit in the status byte is tested for a one or zero. The Condition Code is set to reflect the result of this operation.

If a bit in the v field is zero, the corresponding bit in the status byte is not tested.

Processor Registers Affected CC

Condition Code Setting

	CC1	CC0
All of the selected bits in PSU are 1s	0	0
Not all of the selected bits in PSU are 1s	1	0

TEST PROGRAM STATUS LOWER, SELECTIVE (Immediate Addressing)

Mnemonic TPSL v

Binary Code

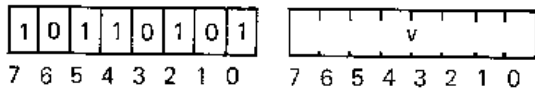

Execution Time 3 cycles (9 clock periods)

Description

This two-byte instruction tests individual bits in the Lower Program Status Byte to determine if they are set to binary one. When this instruction is executed, each bit in the v field of this instruction is tested for a one, and if a particular bit in the v field contains a one, the corresponding bit in the status byte is tested for a one or zero. The Condition Code is set to reflect the result of this operation.

Processor Registers Affected CC

Condition Code Setting	CC1	CC0
All of the selected bits in PSL are 1s	0	0
Not all of the selected bits in PSL are 1s	1	0

ZERO BRANCH RELATIVE (Relative Addressing)

Mnemonic ZBRR (*a)

Binary Code

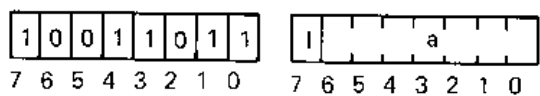

Execution Time 3 cycles (9 clock periods)

Description

This two-byte unconditional relative branch instruction directs the processor to calculate the effective address differently than the usual calculation for the Relative Addressing mode.

The specified value, a, is interpreted as a relative displacement from page zero, byte zero. Therefore, displacement may be specified from -64 to +63 bytes. The address calculation is modulo 8192₁₀, so the negative displacement actually will develop addresses at the end of page zero. For example, ZBRR -8, will develop an effective address of 8184₁₀, and a ZBRR +52 will develop an effective address of 52₁₀.

This instruction causes the processor to clear, address bits 13 and 14, the page address bits; and to replace the contents of the Instruction Address Register with the effective address of the instruction. This instruction may be executed anywhere within addressable memory.

Indirect addressing may be specified.

Processor Registers Affected None

Condition Code Setting N/A

BRANCH ON CONDITION TRUE, RELATIVE

(Relative Addressing)

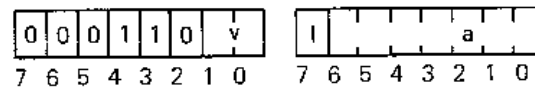
Mnemonic BCTR,v (*)a**Binary Code****Execution Time** 3 cycles (9 clock periods)**Description**

This two-byte conditional branch instruction causes the processor to fetch the next instruction to be executed from the memory location pointed to by the effective address only if the two-bit v field matches the current Condition Code field (CC) in the Program Status Word.

If the v field and CC field do not match, the next instruction is fetched from the location following the second byte of this instruction.

Indirect addressing may be specified.

If the v field is set to 3_{16} , an unconditional branch is effected.

Processor Registers Affected None**Condition Code Setting** N/A

BRANCH ON CONDITION TRUE, ABSOLUTE

(Absolute Addressing)

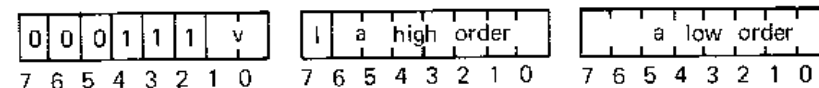
Mnemonic BCTA,v (*)a**Binary Code****Execution Time** 3 cycles (9 clock periods)**Description**

This three-byte conditional branch instruction causes the processor to fetch the next instruction to be executed from the memory location pointed to by the effective address only if the two-bit v field matches the two-bit Condition Code field (CC) in the Program Status Word.

If the v field and CC field do not match, the next instruction is fetched from the location following the second byte of this instruction.

Indirect addressing may be specified.

If the v field is set to 3_{16} , an unconditional branch is effected.

Processor Registers Affected None**Condition Code Setting** N/A

BRANCH ON CONDITION FALSE, RELATIVE(Relative Addressing)

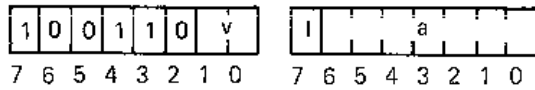
Mnemonic BCFR,v (*)a**Binary Code****Execution Time** 3 cycles (9 clock periods)**Description**

This two-byte branch instruction causes the processor to fetch the next instruction to be executed from the memory location pointed to by the effective address only if the two-bit v field does not match the two-bit Condition Code field (CC) in the Program Status Word. If there is no match, the contents of the Instruction Address Register are replaced by the effective address.

If the v field and CC field match, the next instruction is fetched from the location following the second byte of this instruction.

Indirect addressing may be specified.

The v field may not be set to 3₁₆ as this bit combination is used for the ZBRR operation code.

Processor Registers Affected None**Condition Code Setting** N/A

BRANCH ON CONDITION FALSE, ABSOLUTE(Absolute Addressing)

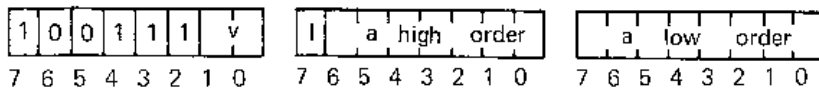
Mnemonic BCFA,v (*)a**Binary Code****Execution Time** 3 cycles (9 clock periods)**Description**

This three-byte instruction causes the processor to fetch the next instruction to be executed from the memory location pointed to by the effective address only if the two-bit v field does not match the two-bit Condition Code field (CC) in the Program Status Word. If there is no match, the contents of the Instruction Address Register are replaced by the effective address.

If the v field and CC field match, the next instruction is fetched from the location following the second byte of this instruction.

Indirect addressing may be specified.

The v field may not be set to 3₁₆ as this bit combination is used for the BXA operation code.

Processor Registers Affected None**Condition Code Setting** N/A

BRANCH ON INCREMENTING REGISTER, RELATIVE (Relative Addressing)

Mnemonic BIRR,r (*a)

Binary Code

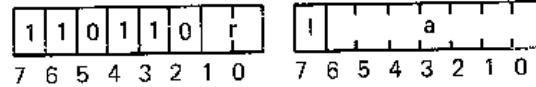

Execution Time 3 cycles (9 clock periods)

Description

This two-byte branch instruction causes the processor to increment the contents of the specified register by one. If the new value in the register is non-zero, the next instruction to be executed is taken from the memory location pointed to by the effective address, i.e., the effective address replaces the previous contents of the Instruction Address Register. If the new value in register r is zero, the next instruction to be executed follows the second byte of this instruction.

Indirect addressing may be specified.

Processor Registers Affected None

Condition Code Setting N/A

BRANCH ON INCREMENTING REGISTER, ABSOLUTE (Absolute Addressing)

Mnemonic BIRA,r (*a)

Binary Code

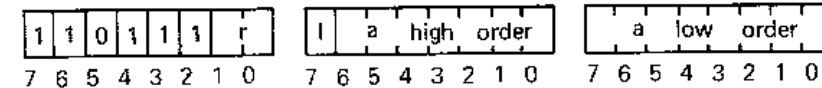

Execution Time 3 cycles (9 clock periods)

Description

This three-byte branch instruction causes the processor to increment the contents of the specified register by one. If the new value in the register is non-zero, the next instruction to be executed is taken from the memory location pointed to by the effective address, i.e., the effective address replaces the previous contents of the Instruction Address Register. If the new value of register r is zero, the next instruction to be executed follows the second byte of this instruction.

Indirect addressing may be specified.

Processor Registers Affected None

Condition Code Setting N/A

BRANCH ON DECREMENTING REGISTER, RELATIVE (Relative Addressing)

Mnemonic BDRR,r (*a)

Binary Code

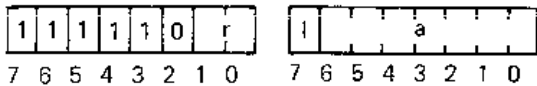

Execution Time 3 cycles (9 clock periods)

Description

This two-byte branch instruction causes the processor to decrement the contents of the specified register by one. If the new value in the register is non-zero, the next instruction to be executed is taken from the memory location pointed to by the effective address, i.e., the effective address replaces the previous contents of the Instruction Address Register. If the new value in register r is zero, the next instruction to be executed follows the second byte of this instruction.

Indirect addressing may be specified.

Processor Registers Affected None

Condition Code Setting N/A

BRANCH ON DECREMENTING REGISTER, ABSOLUTE (Absolute Addressing)

Mnemonic BDRA,r (*a)

Binary Code

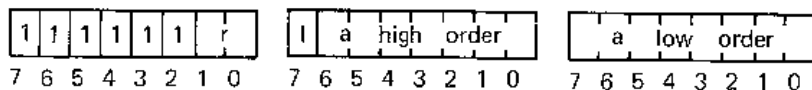

Execution Time 3 cycles (9 clock periods)

Description

This three-byte instruction causes the processor to decrement the contents of the specified register by one. If the new value in the register is non-zero, the next instruction to be executed is taken from the memory location pointed to by the effective address, i.e., the effective address replaces the previous contents of the Instruction Address Register. If the new address in register r is zero, the next instruction to be executed follows the second byte of this instruction.

Indirect addressing may be specified.

Processor Registers Affected None

Condition Code Setting N/A

BRANCH ON REGISTER NON-ZERO, RELATIVE(Relative Addressing)

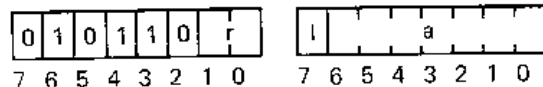
Mnemonic BRNR,r (*)a**Binary Code****Execution Time** 3 cycles (9 clock periods)**Description**

This two-byte branch instruction causes the contents of the specified register r to be tested for a non-zero value. If the register contains a non-zero value, the next instruction to be executed is taken from the location pointed to by the effective address, i.e., the effective address replaces the current contents of the Instruction Address Register.

If the specified register contains a zero value, the next instruction is fetched from the location following the second byte of this instruction.

Indirect addressing may be specified.

Processor Registers Affected None**Condition Code Setting** N/A

BRANCH ON REGISTER NON-ZERO, ABSOLUTE(Absolute Addressing)

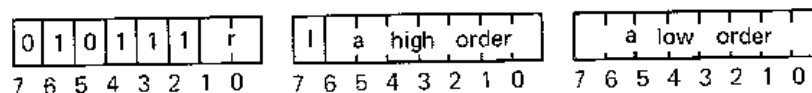
Mnemonic BRNA,r (*)a**Binary Code****Execution Time** 3 cycles (9 clock periods)**Description**

The three-byte branch instruction causes the contents of the specified register r to be tested for a non-zero value. If the register contains a non-zero value, the next instruction to be executed is taken from the location pointed to by the effective address, i.e., the effective address replaces the contents of the Instruction Address Register.

If the specified register contains a zero value, the next instruction is fetched from the location following the third byte of this instruction.

Indirect addressing may be specified.

Processor Registers Affected None**Condition Code Setting** N/A

BRANCH INDEXED, ABSOLUTE(Absolute Addressing)

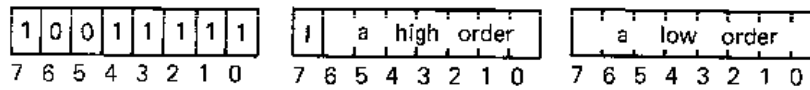
Mnemonic BXA (*a,X**Binary Code****Execution Time** 3 cycles (9 clock periods)**Description**

This three-byte branch instruction causes the processor to perform an unconditional branch. Indexing is required and register #3 must be specified as the index register because the entire first byte of this instruction is decoded by the processor. When executed, the content of the Instruction Address Register (IAR) is replaced by the effective address.

If indirect addressing is specified, the value in the index register is added to the indirect address to calculate the effective branch address.

Processor Registers Affected None**Condition Code Setting** N/A

ZERO BRANCH TO SUBROUTINE, RELATIVE(Relative Addressing)

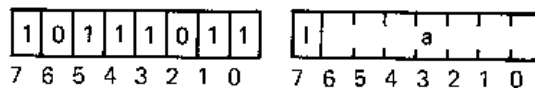
Mnemonic ZBSR (*a**Binary Code****Execution Time** 3 cycles (9 clock periods)**Description**

This two-byte unconditional subroutine branch instruction directs the processor to calculate the effective address differently than the usual calculation for the Relative Addressing mode.

The specified value a is interpreted as a relative displacement from page zero, byte zero. Therefore, displacement may be specified from -64 to +63 bytes. The address calculation is modulo 8192_{10} , so the negative displacement will develop addresses at the end of page zero. For example, ZBSR -10, will develop an effective address of 8182_{10} , and ZBSR 31 will develop an effective address of 31_{10} .

This instruction causes the processor to clear the page address bits, address bits 14 and 13, and may be executed anywhere within addressable memory.

Indirect addressing may be specified.

When executed, this instruction causes the Stack Pointer to be incremented by one, the address of the byte following this instruction is pushed into the Return Address Stack (RAS), and control is transferred to the effective address.

Processor Registers Affected SP**Condition Code Setting** N/A

BRANCH TO SUBROUTINE ON CONDITION TRUE, RELATIVE (Relative Addressing)

Mnemonic BSTR,v (*)a

Binary Code



Execution Time 3 cycles (9 clock periods)

Description

This two-byte conditional subroutine branch instruction causes the processor to perform a subroutine branch *only* if the two-bit v field matches the current Condition Code field (CC) in the Program Status Word. If the fields match, the Stack Pointer is incremented by one and the current contents of the Instruction Address Register, which points to the byte following this instruction, is pushed into the Return Address Stack. The effective address replaces the previous contents of the IAR.

If the v field and CC field do not match, the next instruction is fetched from the location following the second byte of this instruction and the SP is unaffected.

Indirect addressing may be specified.

If v is set to 3₁₆, the BSTR instruction branches unconditionally.

Processor Registers Affected	SP
Condition Code Setting	N/A

BRANCH TO SUBROUTINE ON CONDITION TRUE, ABSOLUTE (Absolute Addressing)

Mnemonic BSTA,v (*)a

Binary Code

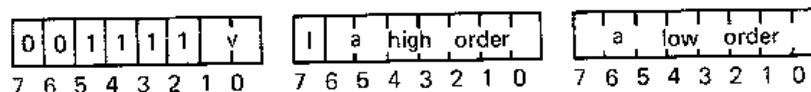

Execution Time 3 cycles (9 clock periods)

Description

This three-byte conditional subroutine branch instruction causes the processor to perform a subroutine branch *only* if the two-bit v field matches the current Condition Code Field (CC) in the Program Status Word. If the fields match, the Stack Pointer is incremented by one and the current contents of the Instruction Address Register, which points to the byte following this instruction is pushed into the Return Address Stack. The effective address replaces the previous contents of the IAR.

If the v field and the CC field do not match, the next instruction is fetched from the location following the third byte of this instruction and the Stack Pointer is unaffected.

Indirect addressing may be specified.

If v is set to 3₁₆, the BSTA instruction branches unconditionally.

Processor Registers Affected	SP
Condition Code Setting	N/A

BRANCH TO SUBROUTINE ON CONDITION FALSE, RELATIVE (Relative Addressing)

Mnemonic BSFR,v (*)a

Binary Code

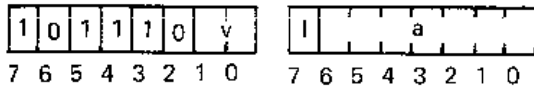

Execution Time 3 cycles (9 clock periods)

Description

This two-byte conditional subroutine branch instruction causes the processor to perform a subroutine branch *only* if the two-bit v field does *not* match the current Condition Code field (CC) in the Program Status Word. If the fields do not match, the Stack Pointer is incremented by one and the current content of the Instruction Address Register, which points to the location following this instruction, is pushed into the Return Address Stack. The effective address replaces the previous contents of the IAR.

If the v field and the CC match, the next instruction is fetched from the location following this instruction and the SP is unaffected.

Indirect addressing may be specified.

The v field may not be coded as 3₁₆ because this combination is used for the ZBSR operation code.

Processor Registers Affected SP
 Condition Code Setting N/A

BRANCH TO SUBROUTINE ON CONDITION FALSE, ABSOLUTE (Absolute Addressing)

Mnemonic BSFA,v (*)a

Binary Code

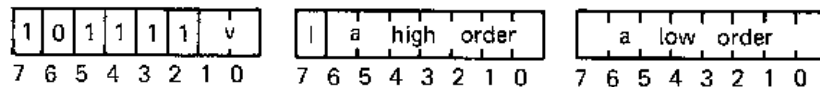

Execution Time 3 cycles (9 clock periods)

Description

This three-byte conditional subroutine branch instruction causes the processor to perform a subroutine branch *only* if the two-bit v field does *not* match the current Condition Code (CC) in the Program Status Word. If the fields do not match, the Stack Pointer is incremented by one and the current content of the Instruction Address Register, which points to the location following this instruction, is pushed into the Return Address Stack. The effective address replaces the previous contents of the IAR.

If the v field and the CC match, the next instruction is fetched from the location following this instruction and the SP is unaffected.

Indirect addressing may be specified.

The v field may not be coded as 3₁₆ as this combination is used for the BSXA operation code.

Processor Registers Affected SP
 Condition Code Setting N/A

BRANCH TO SUBROUTINE ON NON-ZERO REGISTER, RELATIVE

(Relative Addressing)

Mnemonic BSNR,r (*a)

Binary Code

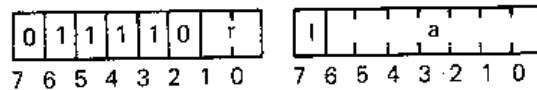

Execution Time 3 cycles (9 clock periods)

Description

This two-byte subroutine branch instruction causes the contents of the specified register r to be tested for a non-zero value. If the register contains a non-zero value, the next instruction to be executed is taken from the location pointed to by the effective address. Before replacing the contents of the Instruction Address Register with the effective address, the Stack Pointer (SP) is incremented by one and the address of the byte following the instruction is pushed into the Return Address Stack (RAS).

If the specified register contains a zero value, the next instruction is fetched from the location following this instruction.

Indirect addressing may be specified.

Processor Registers Affected	SP
Condition Code Setting	N/A

BRANCH TO SUBROUTINE ON NON-ZERO REGISTER, ABSOLUTE

(Absolute Addressing)

Mnemonic BSNA,r (*a)

Binary Code

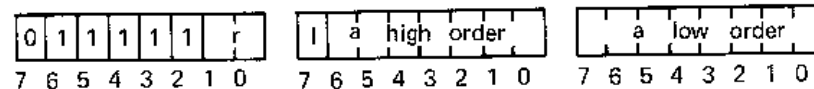

Execution Time 3 cycles (9 clock periods)

Description

This three-byte subroutine branch instruction causes the contents of the specified register r to be tested for a non-zero value. If the register contains a non-zero value, the next instruction to be executed is taken from the location pointed to by the effective address. Before replacing the current contents of the Instruction Address Register (IAR) with the effective address, the Stack Pointer (SP) is incremented by one and the address of the byte following the instruction is pushed into the Return Address Stack (RAS).

If the specified register contains a zero value, the next instruction is fetched from the location following this instruction.

Indirect addressing may be specified.

Processor Registers Affected	SP
Condition Code Setting	N/A

BRANCH TO SUBROUTINE INDEXED, ABSOLUTE, UNCONDITIONAL

(Absolute Addressing)

Mnemonic BSXA (**a*),*X*

Binary Code

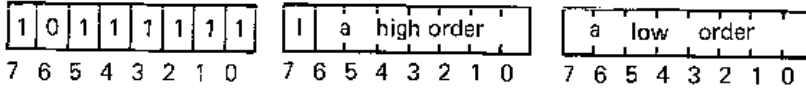

Execution Time 3 cycles (9 clock periods)

Description

This three-byte instruction causes the processor to perform an unconditional subroutine branch. Indexing is required and register #3 must be specified as the index register because the entire first byte of this instruction is decoded by the processor.

Execution of this instruction causes the Stack Pointer (SP) to be incremented by one, the address of the byte following this instruction is pushed into the Return Address Stack (RAS), and the effective address replaces the contents of the Instruction Address Register.

If indirect addressing is specified, the value in the index register is added to the indirect address to calculate the effective address.

Processor Registers Affected SP

Condition Code Setting N/A

RETURN FROM SUBROUTINE, CONDITIONAL

Mnemonic RETC,*v*

Binary Code

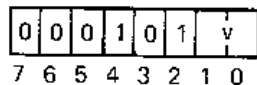

Execution Time 3 cycles (9 clock periods)

Description

This one-byte instruction is used by a subroutine to conditionally effect a return of control to the program which last issued a subroutine branch instruction.

If the two-bit *v* field in the instruction matches the Condition Code field (CC) in the Program Status Word, the following action is taken: The address contained in the top of the Return Address Stack replaces the previous contents of the Instruction Address Register (IAR), and the Stack Pointer is decremented by one.

If the *v* field does not match CC, the return is not effected and the next instruction to be executed is taken from the location following this instruction.

If *v* is specified as 3₁₆, the return is executed unconditionally.

Processor Registers Affected SP

Condition Code Setting N/A

RETURN FROM SUBROUTINE AND ENABLE INTERRUPT, CONDITIONAL

Mnemonic RETE,v

Binary Code

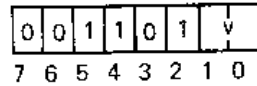

Execution Time 3 cycles (9 clock periods)

Description

This one-byte instruction is used by a subroutine to conditionally effect a return of control to the program which last issued a subroutine branch instruction. Additionally, if the return is effected, the Interrupt Inhibit (II) bit in the Program Status Word is cleared to zero, thus enabling interrupts. This instruction is mainly intended to be used by an interrupt handling routine because receipt of an interrupt causes a subroutine branch to be effected and the Interrupt Inhibit bit to be set to 1. The interrupt handling routine must be able to return and enable simultaneously so that the interrupt routine cannot be interrupt unless that is specifically desired.

If the two-bit v field in the instruction matches the Condition Code field (CC) in the Program Status Word, the following action is taken: The address contained in the top of the Return Address Stack (RAS) replaces the previous contents of the Instruction Address Register (IAR), the Stack Pointer is decremented by one and the II bit is cleared to zero.

If the v field does not match CC, the return is not effected and the next instruction to be executed is taken from the location following this instruction.

If v is specified as $\mathfrak{3}_{16}$, the return is executed unconditionally.

Processor Registers Affected	SP, II
Condition Code Setting	N/A

READ DATA

(Register Addressing)

Mnemonic REDD,r

Binary Code

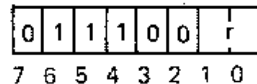

Execution Time 2 cycles (6 clock periods)

Description

This one-byte input instruction causes a byte of data to be transferred from the data bus into register r. Signals on the data bus are considered to be true signals, i.e., a high level will be set into the register as a one.

When executing this instruction, the processor raises the Operation Request (OPREQ) line, simultaneously switching the M/ $\bar{I}O$ line to $\bar{I}O$ and the \bar{R}/W to \bar{R} (Read). Also, during the OPREQ signal, the D/ \bar{C} line switches to D (Data) and the E/ $\bar{N}E$ switches to $\bar{N}E$ (Non-extended).

See Input/Output section of this manual.

Processor Registers Affected	CC		
Condition Code Setting	Register r	CC1	CC0
	Positive	0	1
	Zero	0	0
	Negative	1	0

READ CONTROL(Register Addressing)

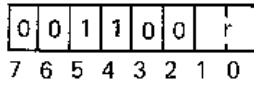
Mnemonic REDC,r**Binary Code****Execution Time** 2 cycles (6 clock periods)**Description**

This one-byte input instruction causes a byte of data to be transferred from the data bus into register r. Signals on the data bus are considered to be true signals, i.e., a high level will be set into the register as a one.

When executing this instruction, the processor raises the Operation Request (OPREQ) line, simultaneously switching the M/ \overline{IO} line to \overline{IO} , the R/W line to \overline{R} (Read), the D/ \overline{C} line to \overline{C} (Control), and the E/ \overline{NE} line to \overline{NE} (Non-extended).

See Input/Output section of this manual.

Processor Registers Affected	CC
Condition Code Setting	Register r CC1 CC0
	Positive 0 1
	Zero 0 0
	Negative 1 0

READ EXTENDED(Immediate Addressing)

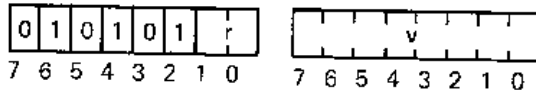
Mnemonic REDE,r v**Binary Code****Execution Time** 3 cycles (9 clock periods)**Description**

This two-byte input instruction causes a byte of data to be transferred from the data bus into register r. During the execution of this instruction, the content of the second byte of this instruction is made available on the address bus. Signals on the data bus are true signals, i.e., a high level is interpreted as a one.

During execution, the processor raises the Operation Request (OPREQ) line, simultaneously placing the contents of the second byte of the instruction on the address bus. During the OPREQ signal, the M/ \overline{IO} line is switched to \overline{IO} , the R/W line to \overline{R} (Read), line and the E/ \overline{NE} line to E (Extended).

See Input/Output section of this manual.

Processor Registers Affected	CC
Condition Code Setting	Register r CC1 CC0
	Positive 0 1
	Zero 0 0
	Negative 1 0

WRITE DATA(Register Addressing)

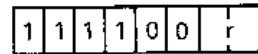
Mnemonic WRTD,*r***Binary Code**

7 6 5 4 3 2 1 0

Execution Time 2 cycles (6 clock periods)**Description**

This one-byte output instruction causes a byte of data to be made available to an external device. The byte to be output is taken from register *r* and made available on the data bus. Signals on the data bus are true signals, i.e., high levels are ones.

When executing this instruction, the processor raises the Operation Request (OPREQ) line and simultaneously places the data on the Data Bus. Along with the OPREQ, the $\overline{M/\overline{IO}}$ line is switched to \overline{IO} , the $\overline{R/W}$ signal is switched to *W* (Write), and a Write Pulse (WRP) is generated. Also, during the valid OPREQ signals, the $\overline{D/\overline{C}}$ line is switched to *D* (Data) and the $\overline{E/\overline{NE}}$ line is switched to \overline{NE} (Non-extended).

See Input/Output section of this manual.

Processor Registers Affected None**Condition Code Setting** N/A

WRITE CONTROL(Register Addressing)

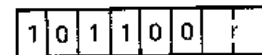
Mnemonic WRTC,*r***Binary Code**

7 6 5 4 3 2 1 0

Execution Time 2 cycles (6 clock periods)**Description**

This one-byte output instruction causes a byte of data to be made available to an external device.

The byte to be output is taken from register *r* and made available on the data bus. Signals on the data bus are true signals, i.e., high levels are ones

When executing this instruction, the processor raises the Operation Request (OPREQ) line and simultaneously places the data on the Data Bus. Along with the OPREQ signal, the $\overline{M/\overline{IO}}$ line is switched to \overline{IO} , the $\overline{R/W}$ signal is switched to *W* (Write), the $\overline{D/\overline{C}}$ line is switched to \overline{C} (Control), the $\overline{E/\overline{NE}}$ is switched to \overline{NE} (Non-extended), and a Write Pulse (WRP) is generated.

See the Input/Output section of this manual.

Processor Registers Affected None**Condition Code Setting** N/A

WRITE EXTENDED

(Immediate Addressing)

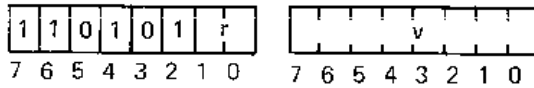
Mnemonic WRTE,r v**Binary Code****Execution Time** 3 cycles (9 clock periods)**Description**

This two-byte output instruction causes a byte of data to be made available to an external device. The byte to be output is taken from register r and is made available on the data bus. Simultaneously, the data in the second byte of this instruction is made available on the address bus. The second byte, v, may be interpreted as a device address.

Signals on the busses are true levels, i.e., high levels are ones.

When executing this instruction, the processor raises the Operation Request (OPREQ) line and simultaneously places the data from register r on the data bus and the data from the second byte of this instruction on the address bus. Along with OPREQ, the M/\overline{IO} line is switched to \overline{IO} , the \overline{R}/W line is switched to W (Write), the E/\overline{NE} line is switched to E (Extended), and a Write Pulse (WRP) is generated.

See the Input/Output section of this manual.

Processor Registers Affected None**Condition Code Setting** N/A

NO OPERATION

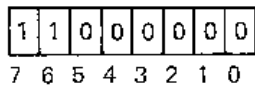
Mnemonic NOP**Binary Code****Execution Time** 2 cycles (6 clock periods)**Description**

This one-byte instruction causes the processor to take no action upon decoding it. No registers are changed, but fetching and executing a NOP instruction requires two processor cycles.

Processor Registers Affected None**Condition Code Setting** N/A

Mnemonic TMI,r v

Binary Code

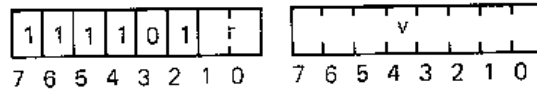

Execution Time 3 cycles (9 clock periods)

Description

This two-byte instruction tests individual bits in the specified register r to determine if they are set to binary one. During execution, each bit in the v field of the instruction is tested for a one, and if a particular bit in the v field contains a one, the corresponding bit in register r is tested for a one or zero. The condition code is set to reflect the result of the operation.

If a bit in the v field is zero, the corresponding bit in register r is not tested.

Processor Registers Affected CC

Condition Code Setting	<u>CC1</u>	<u>CC0</u>
All of the selected bits are 1s	0	0
Not all of the selected bits are 1s	1	0

DECIMAL ADJUST REGISTER(Register Addressing)

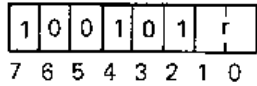
Mnemonic DAR,*r***Binary Code****Execution Time** 3 cycles (9 clock periods)**Description**

This one-byte instruction conditionally adds a decimal ten (two's complement negative six in a four-bit binary number system) to either the high order 4 bits and/or the low order 4 bits of the specified register *r*.

The truth table below indicates the logical operation performed. The operation proceeds based on the contents of the Carry (C) and Interdigit Carry (IDC) bits in the Program Status Word. The C and IDC remain unchanged by the execution of this instruction.

This instruction allows BCD sign magnitude arithmetic to be performed on packed digits by the following procedure.

- BCD Addition:
1. add 66_{16} to augend
 2. perform addition of addend and augend
 3. perform DAR instruction
- BCD Subtraction:
1. perform subtraction (2's complement of subtrahend is added to the minuend)
 2. perform DAR instruction

Since this operation is on sign-magnitude numbers, it is necessary to establish the sign of the result prior to executing in order to properly control the definition of the subtrahend and minuend.

Carry	Interdigit Carry	Added to Register <i>r</i>
0	0	AA_{16}
0	1	$A0_{16}$
1	1	00_{16}
1	0	$0A_{16}$

Processor Registers Affected CC**Condition Code Setting**

The Condition Code is set to a meaningless value.

HALT, ENTER WAIT STATE

Mnemonic HALT

Binary Code

0	1	0	0	0	0	0	0
---	---	---	---	---	---	---	---

7 6 5 4 3 2 1 0

Execution Time 2 cycles (6 clock periods)

Description

This one-byte instruction causes the processor to stop executing instructions and enter the WAIT state. The RUN/ $\overline{\text{WAIT}}$ line is set to the WAIT state.

The only way to enter the RUN state after a HALT has been executed, is to reset the 2650 or to interrupt the processor.

Processor Registers Affected None

Condition Code Setting N/A

CHAPTER III
2650 ASSEMBLER LANGUAGE



INTRODUCTION

The assembly language described in this document is a symbolic language designed specifically to facilitate the writing of programs for the Signetics 2650 processor. The 2650 Assembler is a program which accepts symbolic source code as input and produces a listing and/or an object module as output.

The assembler is written in standard FORTRAN IV and is available either through a timesharing service or in batch form directly from Signetics. This is done to assure compatibility and ease of installation on a user's own computer equipment. It is modular and may be executed in an overlay mode should memory restrictions make that necessary. The program is approximately 1,250 FORTRAN card images in length.

An attempt was made in the design of the language to make it similar to other contemporary assembler languages because it was felt that such similarity would reduce the learning time necessary to become proficient in this language. The 2650 assembler features forward references, self-defining constants, free format source code, symbolic addressing, syntax error checking, load module generation, and source statement listing.

In order to understand the 2650 instruction set, architecture, timing, interface requirements and electrical characteristics, the reader is referred to the Signetics 2650 Hardware Specification section.

The assembler is a two pass program that builds a symbol table, issues helpful error messages, produces an easily readable program listing and outputs a computer readable object (load) module.

The assembler features symbolic and relative addressing, forward references, complex expression evaluations and a versatile set of Pseudo-Operations. These features aid the programmer/engineer in producing well-documented, working programs in a minimum of time. Additionally, the assembler is capable of generating data in several number based systems as well as both ASCII and EBCDIC character codes.

ASSEMBLER LANGUAGE

The assembler language provides a means to create a computer program. The features of the Assembler are designed to meet the following goals:

- Programs should be easy to create
- Programs should be easy to modify
- Programs should be easy to read and understand
- A machine readable, machine language module to be output

This assembler language has been developed with the following features:

- Symbolic machine operation codes (op-codes, mnemonics)
- Symbolic address assignment and references
- Relative addressing
- Data creation statements
- Storage reservation statements
- Assembly listing control statements
- Addresses can be generated as constants
- Character codes may be specified as ASCII or EBCDIC
- Comments and remarks may be encoded for documentation

As Assembly language program is a program written in symbolic machine language. It is comprised of statements. A statement is either a symbolic machine instruction, a pseudo-operation statement, or a comment.

The symbolic machine instruction is a written specification for a particular machine operation expressed by symbolic operation codes and sometimes symbolic addresses or operands. For example:

```
LOC2      STRR, R0    SAV
```

Where:

LOC2 is a symbol which will represent the memory address of the instruction.

STRR is a symbolic op-code which represents the bit pattern of the "store relative" instruction.

R0 is a symbol which has been defined as register 0 by the "EQU pseudo-op".

SAV is a symbol which represents the memory location into which the contents of register 0 are to be stored.

A pseudo-operation statement is a statement which is not translated into a machine instruction, but rather is interpreted as a directive to the assembler program. Example:

```
SCHD      ACON      REDY
```

Where:

ACON is a pseudo-op which directs the assembler program to allocate two bytes of memory.

REDY is a symbol, representing an address. The assembler is directed to place the equivalent memory address into the byte allocated space.

SCHD is a symbol. The assembler is to assign the memory address of the first byte of the two allocated to this symbol.

STATEMENTS

Statements are always written in a particular format. The format is depicted below:

```
LABEL FIELD OPERATION FIELD OPERAND FIELD COMMENT FIELD
```

The statement is always assumed to be written on an 80 column data processing card or an 80 column card image.

The Label Field is provided to assign symbolic names to bytes of memory. If present, the Label Field must begin in logical column one.

The Operation Field is provided to specify a symbolic operation code or a pseudo-operation code. If present, the Operation Field must either begin past column one or be separated from logical column one by one or more blanks.

The Operand Field is provided to specify arguments for the operation in the Operation Field. The Operand Field, if present, is separated from the Operation Field by one or more blanks.

The Comment Field is provided to enable the assembly language programmer to optionally place an English message stating the purpose or intent of a statement or a group of statements. The Comment Field must be separated from the preceding field by one or more blanks.

COMMENT STATEMENT

A Comment Statement is a statement that is not processed by the assembler program. It is merely reproduced on the assembly listing. A Comment Statement is indicated by encoding an asterisk in logic column one. Example:

```
*THIS IS A COMMENT STATEMENT
```

Logical columns 72-80 are never processed by the assembler, they are always reproduced on the assembly listing without processing. This field is a good place for sequence numbers, if desired.

SYMBOLIC ADDRESSING

When writing statements in symbolic machine language, i.e., assembler language, the machine operation code is usually expressed symbolically. For example, the machine instruction that stores data from register 0 into a memory location named SAV, may be expressed as:

```
STRA,R0 SAV
```

The assembler, when translating this symbolic operation code and its arguments into machine language for the 2650, defines three bytes containing H'CC0020', where '0020' is the value of SAV.

The address of the translated bytes is known because the Assembly Program Counter is always set to the address of the next byte to be assembled.

The user can attach a label to an instruction:

```
SAVR STRR,R0 SAV
```

The assembler, upon seeing a valid symbol in the label field, assigns the equivalent address to the label. In the given example, if the STRR instruction is to be stored in the address H'0127', then the symbol SAVR would be made equivalent to the value H'0127' for the duration of the assembly.

The symbol could then be used anywhere in the source program to refer to the address value or, more typically, it could be used to refer to the instruction location. The important concept is that the address of the instruction need not be known; only the symbol need to be used to refer to the instruction location. Thus, when branching to the STRR instruction, one could write:

```
BCTA,3 SAVR
```

When the three byte branch instruction is translated by the assembler,

the address of the STRR instruction is placed in the address field of the branch instruction.

It is also possible to use symbolic addresses which are near other locations to refer to those locations without defining new labels. For example:

	BCTR,3	BEG
	BCTR,0	BEG+4
	ANDZ	3
	BSTR,3	S+48
BEG	LODA,2	PAL
	HALT	
	SUBL,2	3

In the above example, the instruction "BCTR,3 BEG" refers to the LODA,2 PAL instruction. The instruction "BCTR,0 BEG+4" refers to the SUBL,2 3 instruction.

BEG+4 means the address BEG plus four bytes. This type of expression is called relative symbolic addressing and given a symbolic address; it can be used as a landmark to express several bytes before or after the symbolic address. Examples:

	BCTR,3	PAL+23
	BSTA,0	STT-18

The arguments are evaluated like any other expression and cannot exceed in value the maximum number that can be contained in a FORTRAN integer constant.

PROGRAM COUNTER

During the assembly process the assembler maintains a FORTRAN Integer cell that always contains the address of the next memory location to be assembled. This cell is called the Program Counter. It is used by the assembler to assign addresses to assembled bytes, but it is also available to the programmer.

The character "\$" is the only valid symbol containing a special character that the assembler recognizes without error. "\$" is the symbolic name of the Program Counter. It may be used like any other symbol, but it may not appear in the label field.

When using the "\$", the programmer may think of it as expressing the idea "\$" = "address of myself". For example,

108 ₁₆	BCTR,3	\$
-------------------	--------	----

This branch instruction is in location 108₁₆. The instruction directs the microprocessor to "branch to myself". The Program Counter in this example contains the value 108₁₆.

LANGUAGE ELEMENTS

Input to the assembler consists of a sequence of characters combined to form assembly language elements. These language elements include symbols, instruction mnemonics, constants and expressions which make up the individual program statements that comprise a source program.

CHARACTERS

Alphabetic:	A through Z
Numeric:	0 through 9
Special characters:	blank
	(left parenthesis
) right parenthesis
	+ add or positive value
	- subtract or negative value
	* asterisk
	' single quote
	, comma
	/ slash
	\$ dollar sign
	< less than sign
	> greater than sign

SYMBOLS

Symbols are formed from combination of characters. Symbols provide a convenient means of identifying program elements so they can be referenced by other elements.

1. Symbols may consist of 1 to 4 alphanumeric characters: A through Z, 0 through 9.
2. Symbols must begin with an alphabetic character.
3. The character \$ is a special symbol which may be used in the argument field of a statement to represent the current value of the Location Counter.
4. The character * is a special symbol which is used as an indirect address indicator.
5. The characters + and - are also used as auto-increment/auto-decrement indicators.

The following are examples of valid symbols:

DOP1	RAV3
AA	TEMZ

The following are examples of invalid symbols:

1LAR	begins with numeric
PA N	imbedded blank

CONSTANTS

A constant is a self-defining language element. Unlike a symbol, the value of a constant is its own "face" value and is invariant. Internal numbers are represented in 2's complement notation. There are two forms in which constants may be written: the Self-Defining Constant and the General Constant.

SELF-DEFINING CONSTANT

The self-defining constant is a form of constant which is written directly in an instruction and defines a decimal value. For example:

```
LODA,R3    BUFF+65
```

In this example, 65 is a self-defining constant. The maximum value of the integer constant expressed by a self-defining constant is that which, when expressed in binary, will fit within the basic arithmetic unit of the host computer (typically 1 word).

GENERAL CONSTANT

The general constant is also written directly in an instruction, but the interpretation of its value is dictated by a code character and delimited by quotation marks.

```
LODA,R3    BUFF+H'3E'
```

In this example, the code letter H specifies that 3E is a hexadecimal constant equivalent to decimal value 62.

The maximum size of a number generated by a general constant form (B, O, D, H) may be no larger than the size of the FORTRAN integer cell of the host computer. However, the most important concept to understand when using constant forms is that the final value of a resolved expression must fit the constraints of the actual field destined to contain the value. For example:

```
LODA,R2    PAL+H'3EE2'-H'3EE0'
```

In this case, the argument, when resolved, must fit into the 13 bits in the actual machine instruction. Even though each of the two hexadecimal constants are larger than can fit into 13 bits, the final value of the expression is containable in 13 bits and therefore the constants are permitted. Similarly, the statement DATA H'3FE' is not allowed, as the DATA statement defines one byte quantities and H'3FE' specifies more than 8 bits. Summarily, the size of the evaluated expressions must be less than or equal to their corresponding data fields. There are 6 types of General Constants:

Code	Type
B	Binary Constant
O	Octal Constant
D	Decimal Constant
H	Hexadecimal Constant
E	EBCDIC Character Constant
A	ASCII Character Constant

B: BINARY CONSTANT

A binary constant consists of an optionally signed binary number of up to 8 bits enclosed in single quotes and preceded by the letter B, e.g., B'1011011'. Binary information is stored right justified.

O: OCTAL CONSTANT

An octal constant consists of an optionally signed octal number enclosed

by single quotation marks and preceded by the letter O, e.g., O'352'. The value will be right justified.

D: DECIMAL CONSTANT

A decimal constant consists of an optionally signed decimal number enclosed by single quotation marks and preceded by the letter D, e.g., D'249'. The value will be right justified.

H: HEXADECIMAL CONSTANT

A hexadecimal constant consists of an optionally signed hexadecimal number enclosed in single quotation marks and preceded by the letter H, e.g., H'3F'. The value will be right justified.

E: EBCDIC CHARACTER CONSTANT

An EBCDIC character consists of a string of EBCDIC characters enclosed by single quotation marks and preceded by the letter E, e.g., E'ARE YOU THERE?'. Each character will be encoded in 8-bit EBCDIC and stored in successive bytes. The maximum number of characters which may be specified in one character string constant is 16.

A: ASCII CHARACTER CONSTANT

An ASCII character constant consists of a string of ASCII characters enclosed by quotation marks and preceded by the letter A. For example: A'HELLO THERE'. Each character will be encoded in 7-bit ASCII and stored in successive bytes. The high order bit is always set to zero in each allocated byte. Up to 16 characters may be specified in one statement.

Note: See Appendix C for permissible characters and their equivalent ASCII and EBCDIC codes. To specify a single quotation mark as a character constant it must appear twice in the character string, e.g., A'TYPE' 'HELP' 'NOW' will appear in storage as TYPE'HELP'NOW.

MULTIPLE CONSTANT SPECIFICATIONS

General constant forms, except A and E, allow multiple specifications within the constant expression. For example: D'52, 21, 208, 27'. A comma separates each byte specification and successive specifications determine successive bytes of storage. Only 16 bytes of information may be specified in any one general constant form and each byte may be optionally signed. For example:

H'03,-F2,+11,-8,33,0'
O'271,133'.

EXPRESSIONS

An expression is an assembly language element that represents a value. It consists of a single term or a combination of terms separated by arithmetic operators. A term may be a valid symbolic reference, a self-defining constant or a general constant.

It is important to understand that although individual terms in a expression may exceed the number size restriction of the 2650 (one or two bytes), they may not cause the number size of the host computer's integer FORTRAN constant to be exceeded.

Examples of valid expressions:

LOOP	PAL-	\$
LOOP+5	\$-	PAL,+3
SAM+3	LOOP	BIT- 3+H'3H'

Note: The special symbol '\$' represents the current value of the location counter.

SPECIAL OPERATORS

There are two special operators that are recognized by the assembler. They are:

< less than sign
> greater than sign

The assembler interprets these operators in a special way:

< perform a modulo 256 divide (use high order byte)
> perform a divide by 256 (use low order byte)

These operators, when used, must appear as the first character in the argument field. If they are imbedded in an expression, the results are unpredictable.

These special operators are intended to be used to access a two byte address in one byte parts using a minimum of storage. For example, if it is desired to get the high order bits of an address (ADDB) into register 2 and the low order bits into register 1 it could be done as follows:

	LODR,R2	APAL
	LODR,R1	APAL+1
	•••	
	•••	
	•••	
APAL	ACON	ADDB

or, by utilizing the special operators, it could be done as follows:

LODI,R2	<ADDB
LODI,R1	>ADDB

The first method uses 6 bytes to accomplish what the second method can do in 4 bytes.

The special operators are most often used to facilitate the passing of an address in registers.

SYNTAX

Assembly language elements may be combined to symbolically express both 2650 instructions and assembler directives. There are specific rules for writing these instructions. This set of rules is known as the Syntax of the symbolic assembler language. The following description assumes a logical input of an 80-column data processing card, but since the host assembler is written in Fortran, the input media may be magnetic tape, magnetic disk, paper tape, etc. Only the format statement for input need be changed to accommodate the various input media.

FIELDS

A statement prepared for processing by the assembler is logically divided into four fields: the Name Field, the Operation Field, the Argument Field and the Comment Field. Each field is separated by at least one blank character. No continuation cards are allowed, and only logical columns 1 through 72 are scanned by the assembler. Logical columns 73 through 80 inclusive may be used for any desired purpose.

NAME FIELD

The name (or label) field optionally contains a symbolic name which the assembler assigns to the instruction specified in the remaining part of the line. If a name is specified, it must begin in logical column 1. The assembler assumes that there is no name if logical column 1 is blank. The name field, if present, must contain only a valid symbol.

OPERATION FIELD

The operation field contains a mnemonic code which represents a 2650 processor operation or an assembly directive. The operation field must be present in every non-comment line. See Appendix A for a list of the valid mnemonic codes. Additionally, depending on the instruction type, the operation field may also specify a general purpose register or a condition code.

ARGUMENT FIELD

The argument field contains one or more symbols, constants or expressions separated by commas. The argument field specifies storage locations, constants, register specifications and any other information necessary to completely specify a machine operation or an assembler directive. Embedded blanks are not permitted as they are considered field terminators.

COMMENT FIELD

The comment field contains any valid characters in any combination. The comment field is not processed by the assembler, but is merely reproduced on the listing next to the accompanying instruction. It is usually used to explain the purpose or intention of a particular instruction or group of instructions.

COMMENT CARD

An entire 72 column line may be utilized to print comments by coding an asterisk (*) in column 1. This entire card is merely reproduced on the assembly listing without processing by the assembler.

SYMBOLS

Symbols are used in the name field of a symbolic machine instruction to identify that particular instruction and to represent its address. Symbols may be used for other purposes, such as the symbolic representation of some memory address, the symbolic representation of a constant, the symbolic representation of a register, etc.

No matter how the symbol is used, it must be defined. A symbol is defined when the assembler knows what value the symbol represents. There is only one way to define a symbol. The symbol must at some time appear either in the name field of an instruction or of an assembler directive. The symbol will be assigned the current value of the Location Counter when it appears in the name field of a machine instruction, or it may be assigned some other value through use of the EQU assembler directive. A symbol may not appear in the name field more than once in a program, because this would cause the assembler to try to redefine an already defined label. The assembler will not do this and will flag the second appearance of a particular label as an error.

SYMBOLIC REFERENCES

Symbols may be used to refer to storage designations, register assignments, constants, etc. For example:

Address	Name	Operation	Argument
101	MAZE	DATA	H'F5'
102		LODA,3	MAZE

The symbolic label "MAZE" represents the address 101. It is used in the machine instruction at address 102 to tell the assembler to build an instruction LODA,3 101. The symbolic label, in this case, is a way for the programmer to specify an address without knowing exactly what the address should be when he writes the program. In this example, assume there was a need to modify this sequence of code: a data statement was inserted between the original two statements.

Address	Name	Operation	Argument
99	MAZE	DATA	H'F5''
9A,9B		DATA	H'FE,3A'
9C		LODA,3	MAZE

Even though there was a program change which caused the data at MAZE to be located at address 99, the load instruction referencing the data didn't have to be rewritten because the assembler could provide the proper physical address for the symbolic address MAZE. The instruction at address 9C will be assembled as LODA,3 99.

SYMBOLIC ADDRESSING

When writing instructions in the symbolic assembler language for the 2650, the addresses may be expressed through symbolic equivalents. The assembler will translate the symbolic address to its numeric equivalent during the assembly process.

It is good programming practice to make all address references symbolic, as this greatly eases the programmer's job in producing a working program. To make the register specification symbolic, one could equate a symbol to the register number:

```
RG3      EQU      3
          . . .
          . . .
          . . .
          . . .
          LODA,RG3  MAZE
```

FORWARD REFERENCES

A previously defined symbol is one which has appeared in the name field before it is referenced (as above). In contrast, a forward reference is a symbolic reference to a line of code when the symbol has not yet appeared in the name field. For example:

```
          ADDA,2    COEF
          . . .
          . . .
          . . .
COEF      DATA    D'123'
```

Forward references may be used anywhere in a program with the following exceptions:

1. The register/condition field.
2. The symbolic argument fields of EQU, RES, ORG and DATA statements.

RELATIVE ADDRESSING

The programmer may reference a memory cell either directly or via relative addressing. To refer directly to a memory cell of symbolic address MAIN, one has merely to use the name MAIN in the argument field of the referencing instruction. For example:

```
BIRA,R2  MAIN
```

It is also possible to express the address of a memory cell symbolically if some nearby cell is symbolically assigned. For example, to load the memory cell which is 5 cells higher in memory than the cell named MAIN, one need only to refer to it as MAIN+5:

```
LODA,2   MAIN+5
```

This later method is called relative addressing, and the relative count may be given as + or - the maximum value which can be held in one integer variable of the host computer's FORTRAN compiler.

THE LOCATION COUNTER AND SYMBOL "\$"

There is one symbolic name, "\$", which is automatically defined by the assembler. This single character name is always symbolically equated to the assembler's Location Counter. Since the Location Counter is used by the assembler during the assembly process and is usually equated to the address

of the next byte to be assembled, it represents the address of the instruction or data currently being specified. For example: BCTR,3 \$+5. The branch address will be interpreted by the assembler to be the address of the first byte of the branch instruction plus 5 bytes.

HARDWARE RELATIVE ADDRESSING

When using instructions which use "hardware relative addressing" (as distinguished from relative addressing discussed earlier in this section), it is important to realize the assembler will not only evaluate the expression which is given as an operand address, but will convert it to a hardware relative address (see the Hardware Specifications manual for a description of the addressing modes). For example:

Address	Name	Operation	Argument
100	SAM	LODA,R2	PAL
103		SUBI,R2	-3
105		BIRR,R3	SAM
107	next instruction		

In this code, the BIRR instruction specifies hardware relative addressing. Even though the equivalent value of the symbolic address SAM is 100, the relative addressing instruction requires a displacement relative to the address of the next sequential instruction. Therefore, the operand SAM will be evaluated as $-(\text{current location counter} + \text{length of BIRR instruction} - \text{SAM}) = -(105 + 2 - 100) = -(+7) = -7$. Remember, where the hardware instruction calls for "hardware relative addressing", the expression in the operand field will be evaluated as the displacement from the address of the next sequential instruction. The value of this displacement may range from -64 to +63.

INDIRECT ADDRESSING

The symbol "*" is used to specify indirect addressing. For example:

	BCTA,3	*SAM
	•••	
	•••	
	•••	
SAM	ACON	SUBR

In this code, the BCTA instruction specifies indirect addressing. The assembler will set the indirect bit (byte #1, bit #7) for this instruction.

AUTO-INCREMENT AND AUTO-DECREMENT

The symbol "+" and "-" are used to specify auto-increment and auto-decrement, respectively. For example:

LODA,R0 BUF,R3,+

In this code, which specifies auto-increment, the assembler sets bits #6 and #5 of byte #1 to "01" for this instruction. This option is specified in the instruction set tables as (,X).

PROCESSOR INSTRUCTIONS

2650 machine instructions may be written in symbolic code. All features provided by the assembler such as symbolic addressing and constant generation may be used. The fields described below are free form and are separated by at least one blank character. The name, however, if present, must begin in logical column 1.

LABEL	OPERATION	OPERAND	COMMENTS
name	opcode	operand(s)	

Where:

LABEL FIELD contains an optional label which the assembler will assign as the symbolic address of the first byte of the instruction.

OPERATION FIELD contains any of the 2650 processor mnemonic operation codes as detailed in Appendix A, or any Assembler Directive. This field may include an expression which specifies a register or value as required by the instruction. All symbols used in this field must have been previously defined, i.e., no symbolic forward references are allowed.

OPERAND FIELD contains one or more operand elements such as indirect address indicator, operand expression, index register specification, auto-increment/auto-decrement indicator, constant specification, etc., depending on the requirements of the particular instruction.

COMMENTS FIELD any characters following the argument field will be reproduced in the assembly listing without processing. The Comments Field must be separated from the argument field by at least one blank.

Note: Refer to Appendix E for a summary of the mnemonic op-codes and see 2650 Hardware Specifications.

DIRECTIVES TO THE 2650 ASSEMBLER

There are eleven directives which the assembler will recognize. These assembler directives, although written much like processor instructions, are simply commands to the assembler instead of to the processor. They direct the assembler to perform specific tasks during the assembly process, but have no meaning to the 2650 processor. These assembler directives are:

ORG
EQU
ACON
DATA
RES
END
EJE
PRT
SPC
TITL
PCH

ORG SET LOCATION COUNTER

The ORG directive sets the assembly Location Counter to the location specified. The assembler assumes an ORG 0 at the beginning of the program if no ORG statement is given.

LABEL	OPERATION	OPERAND
{name}	ORG	expression

Where:

name optionally provides a symbol whose value will be equated to the specified location.

expression when evaluated, results in a positive integer value. This value will replace the contents of the location counter, and bytes, subsequently assembled will be assigned sequential memory addresses beginning with this value. Any symbols which appear in the argument must have been previously defined.

Examples:

```
LARR        ORG        YORD
STAR        ORG        H'100'
```

EQU SPECIFY A SYMBOL EQUIVALENCE

The EQU directive tells the assembler to equate the symbol in the name field with the evaluable expression in the argument field.

LABEL	OPERATION	OPERAND
name	EQU	expression

Where:

name is the symbol which is to be assigned some value by the execution of this directive.

expression may be resolved to zero or some integer value which is containable in the host computer's FORTRAN integer cell. If a symbol is used in the argument, it must have been previously defined.

Examples:

```
PAL      EQU      H'10F'  
LOP2     EQU      PAL  
RAMP     EQU      SLOP-3+PAL  
REG1     EQU      1
```

ACON DEFINE ADDRESS CONSTANT

The ACON directive tells the assembler to allocate two successive bytes of storage. The evaluated argument will be stored in the two bytes, the low order 8 bits in the second byte and the high order bits in the first byte. This directive is mainly intended to provide a double byte containing an address for use as the indirect address for any instruction executing in the indirect addressing mode.

LABEL	OPERATION	OPERAND
{ name }	ACON	expression

Where:

name is an optional label. If specified, the name becomes the symbolic address of the first byte allocated.

expression is some expression which must resolve to a positive value or zero. If positive, the value should be no larger than that which can be contained in two bytes.

Example:

ASUB ACON SUBR

DATA DEFINES MEMORY DATA

The DATA directive tells the assembler to allocate the exact number of bytes required to hold the data specified in the argument field of this directive. Up to 16 bytes can be specified with one DATA directive, but the argument field may not extend past logical column 72.

LABEL	OPERATION	OPERAND
{name}	DATA	expression

Where:

name is an optional label. If used, the name becomes the symbolic address of the first byte allocated by the directive.

expression is a general constant, a self-defining constant or a symbolic address. If a symbol is specified, it must have been previously defined. A multiple constant specification in the argument field will cause a corresponding number of bytes to be allocated. Any other expression that can be resolved to a single value will result in one byte being allocated.

Examples:

```
PAL      DATA      LOOP
          DATA      H'03,22,FC,A1'
          DATA      +127
          DATA      D'28'
```

Note: If the expression evaluates to a value between 0 and 255 the result is an eight bit absolute binary number. DATA +127 results in H'7F'. Also, if the expression evaluates to a value which is less than 0 the result is a 2's complement, binary number. DATA H'-5' results in H'FB'.

RES RESERVE MEMORY STORAGE

The RES directive tells the assembler to reserve contiguous bytes of storage. The number of bytes so reserved is determined by the argument. The reserved bytes are not set to a known value, but rather the effect of this directive is to increment the location counter.

LABEL	OPERATION	OPERAND
{name}	RES	expression

Where:

name is an optional label. If used, the name becomes the symbolic address of the first byte allocated.

expression is some evaluatable expression which must resolve to some positive integer or zero. The value of this expression may not exceed the maximum positive value containable in a FORTRAN cell of the host computer. If a symbol is specified, it must have been previously defined.

Example:

```
LOR      RES      23
MASK     RES      LOR+5
          RES      H'1A'
```

END END OF ASSEMBLY

The END directive informs the assembler that the last statement to be assembled has been input and the assembler may proceed with the assembly. The END directive causes the assembler to communicate the program start address to the object module.

LABEL	OPERATION	OPERAND
	END	expression

Where:

expression may be resolved to the starting address of the program. If this parameter is not specified, the start address is set to zero.

EJE EJECT THE LISTING PAGE

The EJE directive tells the assembler to advance the listing to the top of the next page regardless of the line position on the current listing page.

The directive is used primarily to organize listing for documentation purposes and does not appear in the listing.

LABEL	OPERATION	OPERAND
	EJE	

PRT PRINTER CONTROL

The PRT directive tells the assembler to resume or discontinue printing of the assembled program.

This directive is used primarily to shorten assembly time by listing only that portion of the program which the user needs to see. Only the PRT OFF will appear in the listing.

LABEL	OPERATION	OPERAND
	PRT	{ on } { off }

Note: PRT is set ON at the beginning of an assembly of the assembler.

SPC SPACE CONTROL

The SPC directive tells the assembler to skip or space a number of lines.

This directive is used primarily to organize listings for documentation purposes and does not appear in the listing.

LABEL	OPERATION	OPERAND
	SPC	expression

Where:

expression is some evaluable expression which must resolve to some positive integer. If the value of this expression is equal to, or greater than, the number of lines remaining on the page, the effect is the same as the EJE directive.

Example:

SPC 5

TITL TITLE

The TITL directive tells the assembler to skip to the top of the next page and insert a given title into the main header.

This directive is used primarily for documentation purposes and does not appear in the listing.

LABEL	OPERATION	OPERAND
	TITL	expression

Where:

expression is the title information not to exceed forty character positions.

Example:

TITL MAIN PROGRAM SUBROUTINE

PCH PUNCH CONTROL

The PCH directive tells the assembler to selectively resume or discontinue the output of the load module.

This directive is used primarily to shorten assembly time when a load module is not desired or when only a portion of the load module is desired.

LABEL	OPERATION	OPERAND
	PCH	{ on } { off }

Note: PCH is set ON at the beginning of an assembly by the assembler. When PCH OFF is specified, any prior load module data is output.

THE ASSEMBLY PROCESS

The 2650 assembler translates symbolic source code into machine language instructions. The assembler examines every source statement for syntactic validity and produces the equivalent machine code for the 2650 processor.

This is a two pass assembler, which means, the entire source code is scanned twice by the assembler. On the first pass, all defined labels and their equivalent values are stored in a symbol table, the first byte of every instruction is fully determined, and some errors may be detected. During pass 2, symbolic address references are replaced by their values, errors may be detected, and a listing and load/object module is generated.

SYMBOL TABLE

The assembler builds and maintains a symbol table during the assembly process. The symbol table contains an entry for each symbol in the assembled program. The entry consists of the symbol itself and its value. Up to 400 symbols may be used in each program assembled. If a symbol, which appears in the argument field of an instruction has never been defined (never appeared in the NAME field), the assembler will generate an error code on the listing because it is unable to resolve an undefined symbol and will place zero as the unresolved value in the object module.

LOCATION COUNTER

The assembler maintains a memory cell which it uses as a Location Counter. This Location Counter keeps track of the address of the next byte of storage to be allocated by the assembler. During coding, the programmer may think of the Location Counter as containing the address of the first byte of the instruction being written. In this assembler, the Location Counter is also used to provide load information. This means that the addresses displayed on an assembly listing are the actual addresses which are to contain the corresponding information upon loading of the object program.

ERROR DETECTION

During an assembly, the source program is checked for syntax errors. If errors are found, appropriate notification is given and the assembly proceeds. Although an assembled program containing errors generally will not run properly, it is considered good practice to complete the assembly to locate all errors at one time, rather than terminate it when an error is encountered.

ERROR CODES

As shown in the listing illustration, there are three columns on the listing in which an error indication may appear. An error displayed, in the first column usually indicates that the error was in the Name Field, the second column corresponds to the Operation Field, and the third corresponds to the Argument Field. Sometimes because an error causes the assembler to view the next field incorrectly, a valid field may be flagged as an error. This is a consequence of the free format source language. A good rule is to fix errors in a particular line of code as they are discovered. In this way, erroneously flagged program errors may then be passed as valid.

The following alphabetic characters are printed in the error indicator columns and imply the corresponding message.

- L — Label error. The label contains too many characters, contains invalid characters, has been previously defined, or is an invalid symbol.
- O — Op-code error. The op-code mnemonic has not been recognized as a valid mnemonic.
- R — Register field error. The register field expression could not be evaluated, or when evaluated, was less than 0 or greater than 3, or the register field was not found.
- S — Syntax error. The instruction has violated some syntax rule.
- U — Undefined symbol. There is a symbol in the argument field which has not been previously defined.
- A — Argument error. The argument has been coded in such a way that it cannot be resolved to a unique value.
- P — Paging error. A memory access instruction has attempted to address across a page boundary.
- W — Warning. The assembler has detected a syntactically correct but unusual construction. The error will not be counted and will not inhibit the production of the object module.

USING THE ASSEMBLER

The program is prepared by punching it into cards or otherwise transferring the program statements into a logical card image file. An ORG statement usually occurs early in the program. If no ORG appears, the assembler assumes an ORG 0 to occur before the first assembled statement. An END statement must occur as the last statement. A program written in the 2650 Symbolic Assembler Language should be preceded and possibly followed by control cards for the particular computer system which is being used. Figure 14 shows the control cards for an IBM/370 DOS system. Although the control cards may vary from system to system, the format of the actual 2650 source program will be the same in the system.

The object module produced by the Assembler during pass 2 is directed to the FORTRAN standard device #2, in this instance the card punch. The source program is read by the assembler at standard device #1, the card reader. In some systems the device assignments may be altered if desired, through assign cards. In other systems, however, the assembler must be recompiled with the device numbers desired being set in the main program module.

```

// JOB SPMP-MC01 OLTEA MICROPROCESSOR X2464
// OPERATOR THIS PROG PUNCHES A FEW CARDS; NOTHING X2359
// ASSGN SYS004, SYS001
// DLBL 00LIT, PXGO, WORK, 69/001
// EXTENT SYS004, ***7505, 160
// EXEC CLRUK
// UCL H=(N=0, S=912), X'00', ON, E=13301
// END

// ASSGN SYS006, SYS007
// ASSGN SYS007, SYS001
// DLBL 1, SYS007, PXGO, WORK, 69/001
// EXTENT SYS007, ***7505, 160
// EXEC PXPTASM

```

2650 SOURCE PROGRAM

Figure 14

OBJECT MODULE

The format of the object module is: The first card or card image is always all 9's.

bb9999999999999999

The second and all subsequent data cards are in the following format. Logical columns (1-5) contain the load address in decimal. Each three columns (6-71) contain the data to be loaded in decimal. Each three columns represent a byte of data; columns (6-8), (9-11), (12-14), etc. Beginning at the address indicated in columns (1-5) each sequential data byte is to be loaded into sequentially ascending addresses in memory. If a '999' appears in a particular data byte position, that byte of information is to be ignored by the loader and the contents of the corresponding location is not modified.

Because there is address and data on every card image, each card image is independent. Therefore, the order of the data cards is unimportant and patch cards may be prepared manually by preparing a data card in the object module format.

The last two card images each serve a special purpose. The next to last card contains a series of '-1' punches. This card is used to signal the end of load information and has no other function.

The last card, which follows the '-1' card, contains either the start address (specified in assembler END statement) or zero in columns (1-5), the remainder of the card contains '-1' punches which have no meaning.

ASSEMBLY LISTING

Figure 15 is a sample of a program listing produced by the 2650 Assembler. The following explanations are keyed to the listing.

1. Page heading — which displays the current version and level of the 2650 Assembler.
2. Line number — every assembled line is assigned a line number for the programmer's convenience.
3. Address column — The numbers in this column are equal to the value of the assembly Location Counter and indicate the address at which the first byte (B1) is to be loaded.
4. Label column — If there is a symbol in the Label Field of a line of code, the value of the label will appear in this column. For example, in line number 17 the value of the label SORT is H'0007'.
5. Data field — This field describes the data bytes which are to be stored sequentially starting at the address in the Address Column.
6. Error columns — These columns may contain the error codes as detailed elsewhere in this chapter.
7. Source code — This area of the listing reproduces the source code as it was read by the assembler.
8. Page number — Every page of the listing is numbered sequentially.
9. Cumulative errors — This field indicates the total of errors detected by the assembler during the assembly process. Warning messages (W) are not included in this total.

CHAPTER IV
2650 SIMULATOR

INTRODUCTION

The 2650 Simulator is a FORTRAN program which allows a user to simulate the execution of his program without utilizing the 2650 processor.

The Simulator executes a 2650 program by maintaining its own internal FORTRAN storage registers to describe the 2650 program itself, the micro-processor registers, the ROM/RAM memory configuration, and the input data to be read dynamically from I/O devices. Multiple simulations of the same program may be executed during a single simulation run. In addition, statistical timing information may be generated.

The Simulator requires as input both the program object module produced by the 2650 Assembler and a deck of user commands. It produces a listing of the user's commands, executes the program and prints ("displays") both static and dynamic information as requested by the user's commands.

SIMULATOR OPERATION

GENERAL

Once the Simulator is loaded and started, it performs the following actions:

- Presets each register in simulated memory to a "HALT" instruction. Thus, if the user's program attempts to branch to some undefined area of memory, the current execution of the simulated program is terminated and only relevant data is printed.
- Reads and stores the user's commands. These commands control the performance of the Simulator during program execution. They are stored in a simulator table for reference before, during, and after execution.
- Loads the 2650 object module into simulated memory.
- Starts the simulated program. The simulated program is started at the address specified in the START command. If no START command is submitted, the program is started in the location specified in the END statement of the simulated program (see Assembler manual). If no location is specified in the END statement, the Simulator starts in location 0.
- Oversees the execution of each instruction. Before an instruction is executed, the Simulator checks the address of the instruction and the address of the referenced memory location to see if either of these addresses is referenced by any one of the user's commands. If so, the command is executed. The Simulator then executes the current instruction, updates all affected registers and retrieves the next instruction for execution.
- Terminates the simulated program. The simulation is terminated either by the execution of a "HALT" instruction, or by having executed a preset number of instructions or by having satisfied the conditions of the STOP command.
- Once the execution of one simulation is complete, the Simulator prints any statistical timing information requested (STAT), and proceeds with the next simulation (TEND) or terminates itself (FEND).

SIMULATED PROCESSOR STATE

The Simulator maintains a number of FORTRAN integer cells which are used to simulate the microprocessor's state, i.e. the general purpose registers,

the upper and lower program status bytes, the location counter or instruction address register (IAR), the address of the instruction referenced and the contents of the location referenced.

These simulated registers and status bits may be displayed dynamically, (INSTR., REFER., TRACE.) i.e., while the simulated program is executing. Also the general purpose registers and the status bytes may be altered dynamically (SETR., SETP.).

SIMULATED MEMORY

The Simulator maintains a 2048 cell FORTRAN integer array which is used to simulate read-write random access memory.

It is possible to configure parts of this memory into a ROM-RAM environment by using the SROM Command. If part of the simulated memory is set to Read-Only and an instruction attempts to store data into that memory segment, the Simulator bypasses storing the data, prints a warning message and continues with the next program instruction.

Using Simulator commands, the user may change parts of memory before the program executes (PATCH) and he may display parts of memory dynamically (DUMP.).

The simulated memory is smaller in many cases than the total memory size of the user's physical system. This restriction encourages the construction of modular programs. Because the simulated memory is smaller than a 2650 page, it is not possible to fully test programs which utilize the 2650 paging system, i.e., programs larger than 8192 bytes.

SIMULATED INPUT/OUTPUT INSTRUCTIONS

The Simulator maintains a 200-byte First In, First Out (FIFO) buffer to store the data read from a simulated input device. This buffer must be preset by the user command, INPUT.

When any 2650 input instruction is simulated (REDE, REDC, REDD), the Simulator accesses the buffer. If there is data in the buffer, the next byte of data is inserted in the simulated register specified by the input instruction. If the buffer contents have been exhausted, a warning message is displayed on the simulator listing.

To simulate the execution of any 2650 output instruction (WRTE, WRTC, WRTD), the Simulator takes the data byte from the register specified in the output instruction and displays it along with the address of the output instruction.

USER COMMANDS

GENERAL

The 2650 Simulator accepts commands which specify how the program is to run and what data is to be recorded.

In any one Simulator run, the user may specify that his program be executed any number of times. The user submits a new set of commands for each execution. The final command set is followed by a final end card (FEND), while all prior command sets are terminated with a temporary end card (TEND) (Illust. III-1).

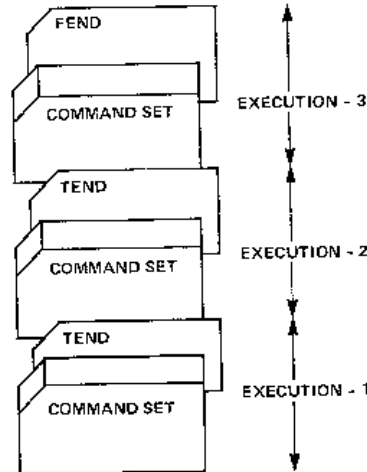

Figure 16. THREE SETS OF COMMANDS

Within any one command set, the user may specify:

- That the program execution start at a specific memory location (START).
- That the execution of the program be complete either when the number of instructions executed equals a specified number (LIMIT) or when the instruction at a specific address executes (STOP.) or when the simulated program itself executes a "HALT" instruction.
- That statistics be displayed at the end of execution (STAT). The Simulator accumulates a count of the total number of instructions executed, the number of each type of instruction executed, and the total number of 2650 machine cycles expended. This information provides a measure of efficiency by indicating how many 1-, 2-, or 3-byte instructions were executed and may be used to calculate program timings.
- That certain areas of simulated memory be designated as Read-Only (SROM) and are therefore inaccessible to any memory write operation.
- That the contents of memory be initialized with specific data (PATCH).
- That a FIFO (First In, First Out) buffer be used to simulate data read from I/O devices (INPUT).
- That the processor state be recorded whenever a specific memory location executes (INSTR.), whenever a specific memory location is referenced (REFER.), or whenever any instruction executes which lies within a specified range of memory addresses (TRACE.). The processor state consists of the location counter, the instruction referenced and its contents, the upper and the lower program status bytes, and the contents of all the general purpose registers.

-
- That an area of memory be dumped whenever an instruction at a specific memory location executes (DUMP.).
 - That certain general purpose registers (SETR.) or the program status bytes (SETP.) be set dynamically, i.e., whenever a specific memory location executes.
 - That comments (**) be interspersed between control cards.

Some of these commands execute dynamically, i.e., when an instruction at a specific memory location executes or when that location is referenced. Since the simulator storage capacity limits the total number of locations which may be retained simultaneously (while a program is executing), a total of 30 memory locations may be specified on all the "dynamic" commands submitted for any one execution, i.e., in any one command set. These dynamic commands are identified by a trailing period (.), e.g., "STOP.". This period is treated as a field separator, i.e., it is not treated as part of the command name by the Simulator and is therefore optional. The description for each dynamic command identifies which of its parameters count toward the 30 "dynamic" command limit, i.e., the limit of 30 memory locations.

In addition, the number of DUMP. commands is limited to five (5); the number of SETR. commands is limited to four (4); the number of SETP. commands is limited to two (2); and the number of data read on all INPUT cards in one command set is limited to 200.

All "dynamic commands" are executed *before* the simulated instruction is executed.

For those commands which accept only one set of parameters (LIMIT, SR0M, START) only the last set of parameters encountered is used.

COMMAND FORMATS

Figure 17 contains a list of the commands, their parameters and a brief description of the commands themselves. In addition, the Simulator treats as a comment card, any card with two consecutive asterisks (**) starting in column 1.

The Simulator accepts information in card image form. The entire card is read in FORTRAN "A" format. A command must be complete on one card as continuation cards are not allowed. Comments may appear in any order within a command set.

The command name starts in column 1 and must appear as shown, except for the optional period.

The field of characters which lies between the command name and its parameters or between the parameters themselves is called a field separator. A field separator may contain any number of characters, but none of these characters may be hexadecimal characters (0-9, A-F). For the sake of clarity in all the examples, the following field separators are used to indicate the following functions:

FIELD SEPARATOR**FUNCTION**

	Identifies a command which counts toward the "dynamic" command limit.
blank (s)	Separate a command from its parameters.
()	Encloses optional parameters.
;	Separates one set of parameters from another.
,	Separates one parameter from another within a set of parameters.
; . . . ;	Indicates that multiple parameters or sets of parameters are legal. If a period flags a command, each of its parameter sets counts toward the "dynamic" command limit. E.g., the following sets of commands are identical: 1. INST. 100 INST. 200 2. INST. 100; 200

The parameters themselves must be hexadecimal numbers (0-9, A-F). The following labels identify parameters in Illustration III-2:

LOC	Location or address of an instruction which is to be executed or the address of data which is to be referenced.
NO	A number of data, e.g., the total number of instructions to be executed.
FWA	First Word Address of some area of memory.
LWA	Last Word Address of some area of memory.
VALUE	The value to which some location is to be set.
R0, R1 . . . R6	General Purpose Registers 0-6.
PSL	Identifies Lower Program Status Byte.
PSU	Identifies Upper Program Status Byte.

COMMAND NAME	PARAMETERS	DESCRIPTION
DUMP.	LOC, FWA-LWA (; . . . ;LOC, FWA-LWA)	Display the area of memory, FWA-LWA, whenever the instruction at LOC executes.
FEND	None	Execute the last simulation and terminate the entire run.
INPUT	VALUE(; . . . ;VALUE)	Define the data to be read by simulated I/O instructions.
INSTR.	LOC(; . . . ;LOC)	Display the processor registers whenever the instruction at LOC executes.
LIMIT	NO	Specify the total number of instructions executed.
PATCH	LOC,VALUE(; . . . ;LOC,VALUE)	Initialize each memory location, LOC, to VALUE.
REFER.	LOC(; . . . ;LOC)	Display the processor register whenever the instruction at LOC is referenced by another instruction.
SETP.	LOC,(PSL=VALUE) (,PSU=VALUE)	Set the program status byte (lower and/or upper) to VALUE whenever the instruction at LOC executes.
SETR.	LOC,(R0=VALUE) . . . (R6=VALUE)	Set the general purpose registers to VALUE whenever the instruction at LOC executes.
SRAM	FWA-LWA	Specify the boundaries of Read-Only Memory.
START	LOC	Start the simulated program execution at LOC.
STAT	None	Display instruction statistics at end of program execution.
STOP.	LOC(; . . . ;LOC)	Terminate the program execution when the instruction at LOC executes.
TEND	None	Execute the last simulation and prepare to read the User Commands for the next simulation.
TRACE.	FWA-LWA(; . . . ;FWA-LWA)	Display the processor registers whenever an instruction executes, which lies within the area of memory, FWA-LWA.

Figure 17. COMMAND SUMMARY

COMMAND DESCRIPTIONS

The following command descriptions are alphabetized by command name. As previously discussed all parameters are entered in hexadecimal notation (0-9, A-F). All address parameters (LOC, FWA, LWA) are limited to the size of simulated memory.

DUMP. DUMP SIMULATED MEMORY

This command causes the Simulator to display selected portions of memory whenever the location counter matches LOC.

Each LOC counts as one "dynamic" command. The total number of "dynamic" commands is limited to thirty (30). The total number of LOC's submitted in DUMP. commands is limited to five (5).

DUMP. LOC,FWA-LWA(; . . . ;LOC,FWA-LWA)

Where: DUMP. is the command name.

LOC is the address of the 2650 instruction at which the dump occurs.

FWA is the first address of the area to be dumped.

LWA is the last address of the area to be dumped. LWA must be larger than FWA.

Example: DUMP. 5A,0-3FF 100-11A-21A
DUMP. EO-400-4FF

Note: More data may be dumped than was specified since the FWA dumped always has a least significant digit of 0, e.g. 30, 100, etc. Similarly, LWA always has a least significant digit of F, e.g. 3F, 10F, etc.

FEND FINAL END COMMAND

This command signals the Simulator that the preceding commands complete the directives for the final simulator run. After **FEND** is read, the Simulator performs the last simulation and comes to its final termination.

FEND

Where: **FEND** — specifies the command name.

Example: **START 1A**
 TRACE 0, 100
 TEND
 START AA
 PATCH 11, C2
 FEND

INPUT DEFINE DATA FOR INPUT

This command loads data into a FIFO storage buffer from which the same data is used to supply I/O instructions with input data. The first data point specified becomes the first one accessed by a 2650 read instruction. The last point specified becomes the last one accessed. Should the buffer become empty during the simulated execution, an error message is printed, the input register remains unchanged and the simulation continues.

Any number of these command cards may be submitted as long as the total number of data specified in one run does not exceed the size of the FIFO storage buffer (200).

INPUT VALUE(; . . . ;VALUE)

Where: **INPUT** — specifies the command name.
 VALUE — specifies a 2-digit hexadecimal value.

Example: **INPUT 0, 1, 2, 3, 10, 1A, FF**

INSTR. INSTRUCTION TRACE

This command sets a break point at the specified address. When the instruction at this address executes, the Simulator prints out the internal state of the simulated processor. The break point occurs before the instruction is executed.

Each address specified in an INSTR. command counts as one "dynamic" command.

INSTR. LOC(; ... ; LOC)

Where: INSTR. — specifies the command.

LOC — specifies the address for a break point. The address must be within simulated memory.

Example: INSTR. 1CE, 1A, 22
INSTR. 123-200-5E
INSTR. 74

LIMIT LIMIT THE NUMBER OF INSTRUCTIONS EXECUTED

This command determines how many instructions will be executed. If the number given in the LIMIT command is exceeded before the instruction specified by a STOP. command executes or before a 2650 HALT instruction is simulated, the Simulator terminates the current program operation.

Without this command, the Simulator assumes a limit of 1000_{10} instructions. The maximum LIMIT which may be specified is determined by the maximum integer constant of the FORTRAN compiler used.

LIMIT NO

Where: LIMIT — specifies the command.

NO — is a number which determines the maximum number of instructions to be executed.

Example: LIMIT 200
LIMIT 2F

PATCH PATCH SIMULATED MEMORY

This command alters the contents of memory before a simulation run. It may be used to alter the contents of any byte in memory and overrides load information in the object module for the duration of one simulation run.

Any number of these commands may be given in a simulator command stream.

PATCH LOC,VALUE(; . . . ;LOC,VALUE)

Where: PATCH — specifies the command.

LOC — specifies the simulated memory address which is to be changed.

VALUE — specifies a 2-digit hexadecimal number to be stored at LOC.

Example: PATCH 0,1F 1,0 2.5E
 PATCH 102,EE

REFER. MEMORY REFERENCE TRACE

This command causes a break point to occur whenever one of the specified addresses is referenced by a simulated instruction. During the break point, the Simulator prints out the internal state of the simulated processor. The data byte of immediate addressing instructions is handled like an ordinary operand address.

Each address specified in a REFER. command counts as one “dynamic” command.

REFER. LOC(;LOC. . . ;LOC)

Where: REFER. — specifies the command.

LOC — specifies the effective operand address for a break point. The address must be within simulated memory.

Example: REFER. 3FF/21/18E
 REFER. 200
 REFER. 5, 50, 22F

SETP. SET PROGRAM STATUS BYTE

The SETP. command dynamically alters the upper and/or the lower program status bytes. The specified program status byte is set when the address parameter supplied in the command, LOC, equals the location counter.

A SETP. command must set at least one program status byte. Up to two SETP. commands may be given in a simulator command stream. Each LOC submitted counts as one "dynamic" command.

The PSL and PSU may be entered in any order.

SETP. LOC(,PSL=VALUE) (,PSU=VALUE)

Where: SETP. — specifies the command.

LOC — specifies the simulated execution address where the program status byte is to be set.

PSL — specifies that a value is to be entered into PSL.

PSU — specifies that a value is to be entered into PSU.

VALUE — specifies the 2-digit hexadecimal value to be entered into the program status byte.

Example: SETP. 5A PSL=05
SETP. 10E, PSL=01 PSU=00

SETR. SET GENERAL PURPOSE REGISTER

This command dynamically sets the general purpose registers during simulated program execution. Using this command, any or all of the general purpose registers can be set when the location counter value is equal to the address parameter, LOC, supplied in this command.

A SETR. command without parameters is not permitted. Up to four SETR. commands may be given in a simulator command stream. Each LOC counts as one "dynamic" command.

Register identifiers may appear in any order.

SETR. LOC(R0=VALUE) . . . (R6=VALUE)

Where: SETR. -- specifies the command.

LOC -- specifies the simulated execution address where the registers are to be set.

R0 -- indicates the general purpose register to be set. R0

R1 always refers to general purpose register 0. R1, R2, and

R2 R3 specify the registers in register bank zero. R4, R5

R3 and R6 specify R1, R2, and R3 in register bank one.

R4

R5

R6

VALUE -- specifies the 2-digit hexadecimal value to be stored in the selected register.

Example: SETR. 10A R1=3F, R2=00, R3=5

SETR. 2F3 R0=FF, R5=00

SROM DEFINE THE BOUNDARIES OF READ ONLY MEMORY

This command allows the user to simulate a Read Only/Read Write Memory environment. Whenever a 2650 instruction attempts to store data in the area defined as Read Only, a warning message is printed on the simulation listing. The data is not actually stored, but the simulation run continues.

SROM FWA-LWA

Where: SROM — specifies the command.

FWA — specifies the first address of the simulated ROM area.

LWA — specifies the last address of the simulated ROM area. LWA must be greater in value than the FWA. The addresses specified are inclusive.

Example: SROM 100-FF

START START SIMULATION

This command specifies the address at which simulated execution begins. The address specified in the START command supersedes the start address in the load object module. The start address in the load object module is set by an END statement during program assembly and is used by the Simulator if no START command is given (see the 2650 Assembler Language Manual for the END statement).

START LOC

Where: START — specifies the command.

LOC — specifies a start address for the program to be simulated.

Example: START 10A
START 2

STAT DISPLAY INSTRUCTION STATISTICS

This command causes a list of 2650 instructions with the number of times each was executed to be printed out at the end of the simulation run.

STAT

Where: STAT — specifies the command.

STOP. STOP SIMULATED EXECUTION

This command terminates the current simulated instruction execution when the location counter matches the command argument, LOC.

Each LOC counts as one “dynamic” command.

STOP. LOC(; . . . ;LOC)

Where: STOP. — specifies the command.

LOC — specifies the instruction address at which simulated execution ceases.

TEND TEMPORARY END COMMAND

This command signals the Simulator that the preceding commands complete the directives for a simulator run. After the TEND is read, the Simulator begins simulated execution of the 2650 program. Because TEND is a temporary end, the Simulator assumes that there is another command stream following it. The last command stream in a simulation run must be terminated with a FEND (final end) command.

TEND

Where: TEND — specifies the command.

Example: PATCH 01, 15 0A, FF
 TEND
 START 100
 PATCH 01, E2 0A, FF
 FEND

TRACE. TRACE PROGRAM FLOW

This command causes break points to occur at each instruction within an area of memory. The user specifies two addresses. If the simulated processor accesses an instruction at an address that falls between the specified addresses, the Simulator prints out the internal state of the simulated processor.

Each set of FWA,LWA counts as one "dynamic" command.

TRACE. FWA-LWA(; . . . ;FWA-LWA)

Where: TRACE. — specifies the command.

FWA — specifies from what address the trace is in effect.

LWA — specifies to what address the trace is in effect. LWA must be larger in value than FWA. The addresses specified are inclusive.

Example: TRACE. 0-15F, 250-3FF
TRACE. 1-A, 3FF-40A
TRACE. 10-1A 50-5A 60-7A

SIMULATOR DISPLAY (LISTING)

As the Simulator reads each command set, it prints the card images of the command set and then executes the program. During program execution the following commands result in some form of display:

DUMP.
INSTR.
REFER.
TRACE.

DUMP. results in the display of an entire area of memory while the last three commands result in some form of trace, i.e., a display of the processor state:

Instruction address register (IAR) or location counter
Instruction executed (INST)
Instruction referenced or effected (EADDR)
Contents of the instruction referenced or effected (EADDR)
Program status byte upper (PSU)
Program status byte lower (PSL)
General purpose registers (R0, R1, R2, R3, R4, R5, R6)

Figures 18 through 21 contain the printout or display output from one Simulator run. Figure 18 shows the first command set, which contains commands to:

- Start at location 0 (START)
- Initialize locations 55-5F, locations 61-6B and location 19 (PATCH)
- Dump locations 55-77 whenever either location 0 or location 3 executes (DUMP)
- Trace locations 14-1A (TRACE)

Figures 18 and 19 show the results of the first command set:

- A dump of locations 55-77. Note that a larger area is dumped than was specified.
- 30 traces
- A final dump of locations 55-77

When the program execution for the first command set is complete, the Simulator reports:

- The number of machine cycles executed
- The number of instructions executed

Figure 20 shows the second command set. It is exactly the same as the first command set except that it initializes locations 12 and 33 instead of location 19.

The output of the second command set is just like the output of the first command set except that it results in 33 traces, not 30.

```

SYST 05
PATCH 35.0 58.1 57.2 58.0 58.1
PATCH 58.5 58.4 58.3 58.2 58.1
PATCH 57.0
PATCH 01.0
PATCH 62.0 63.0 64.1 65.1 66.2
PATCH 67.2 68.3 69.4 70.2 71.1
DUMP 0.25.17
PATCH 19.59
TRACE 14.11
*END

```

```

COMMAND DUMP
0050 17 07 15 18 05 00 01 02 02 03 06 24 03 02 01 00
0060 00 00 00 00 01 01 02 02 03 03 04 04 05 05 06 06
0070 08 00 02 00 00 00 00 00 00 00 00 00 00 00 00 00
TRACE COMMAND
IAR INST EADDR (EADDR) PSBU PSBL 00 R1 R2 R3 R4 R5 R6
0010 LCA+0 0061.3- 0061 0001 01 00 00 04 00 00 00 00 00
TRACE COMMAND
IAR INST EADDR (EADDR) PSBU PSBL 00 R1 R2 R3 R4 R5 R6
0017 0000 0055.1 0055 0000 01 40 01 0A 00 0A 00 00 00
TRACE COMMAND
IAR INST EADDR (EADDR) PSBU PSBL 00 R1 R2 R3 R4 R5 R6
0017 0000 0A 0000 01 40 01 0A 00 0A 00 00 00 00
TRACE COMMAND
IAR INST EADDR (EADDR) PSBU PSBL 00 R1 R2 R3 R4 R5 R6
0017 LCA+0 0061.3- 0061 0002 01 80 01 09 00 0A 00 00 00
TRACE COMMAND
IAR INST EADDR (EADDR) PSBU PSBL 00 R1 R2 R3 R4 R5 R6
0017 0000 0055.1 0055 0001 01 40 02 04 00 00 00 00 00
TRACE COMMAND
IAR INST EADDR (EADDR) PSBU PSBL 00 R1 R2 R3 R4 R5 R6
0017 0000 0A 0000 01 40 03 09 00 09 00 00 00 00
TRACE COMMAND
IAR INST EADDR (EADDR) PSBU PSBL 00 R1 R2 R3 R4 R5 R6
0017 LCA+0 0061.3- 0061 0003 01 80 03 08 00 09 00 00 00
TRACE COMMAND
IAR INST EADDR (EADDR) PSBU PSBL 00 R1 R2 R3 R4 R5 R6
0017 0000 0055.1 0055 0007 01 40 03 08 00 08 00 00 00
TRACE COMMAND
IAR INST EADDR (EADDR) PSBU PSBL 00 R1 R2 R3 R4 R5 R6
0017 0000 0A 0004 01 40 0A 08 00 08 00 00 00
TRACE COMMAND
IAR INST EADDR (EADDR) PSBU PSBL 00 R1 R2 R3 R4 R5 R6
0017 0000 0055.1 0055 0007 01 40 08 08 00 08 00 00 00
TRACE COMMAND
IAR INST EADDR (EADDR) PSBU PSBL 00 R1 R2 R3 R4 R5 R6
0017 0000 0A 0004 01 40 0A 08 00 08 00 00 00
TRACE COMMAND
IAR INST EADDR (EADDR) PSBU PSBL 00 R1 R2 R3 R4 R5 R6
0017 0000 0055.1 0055 0009 01 21 0A 07 00 06 00 00 00
TRACE COMMAND
IAR INST EADDR (EADDR) PSBU PSBL 00 R1 R2 R3 R4 R5 R6
0017 0000 0055.1 0055 0003 01 41 09 07 00 07 00 00 00

```

```

TRACE COMMAND
IAR INST EADDR (EADDR) PSBU PSBL 00 R1 R2 R3 R4 R5 R6
0014 0000 0A 0004 01 40 0C 07 00 07 00 00 00
TRACE COMMAND
IAR INST EADDR (EADDR) PSBU PSBL 00 R1 R2 R3 R4 R5 R6
0014 LCA+0 0061.3- 0061 0002 01 81 02 06 00 07 00 00 00
TRACE COMMAND
IAR INST EADDR (EADDR) PSBU PSBL 00 R1 R2 R3 R4 R5 R6
0017 0000 0055.1 0055 0004 01 61 02 04 00 06 00 00 00
TRACE COMMAND
IAR INST EADDR (EADDR) PSBU PSBL 00 R1 R2 R3 R4 R5 R6
0017 0000 0A 0004 01 40 06 06 00 06 00 00 00
TRACE COMMAND
IAR INST EADDR (EADDR) PSBU PSBL 00 R1 R2 R3 R4 R5 R6
0014 LCA+0 0061.3- 0061 0003 01 80 06 05 00 06 00 00 00
TRACE COMMAND
IAR INST EADDR (EADDR) PSBU PSBL 00 R1 R2 R3 R4 R5 R6
0017 0000 0055.1 0055 0005 01 40 03 05 00 05 00 00 00
TRACE COMMAND
IAR INST EADDR (EADDR) PSBU PSBL 00 R1 R2 R3 R4 R5 R6
0014 0000 0A 0004 01 40 06 05 00 05 00 00 00
TRACE COMMAND
IAR INST EADDR (EADDR) PSBU PSBL 00 R1 R2 R3 R4 R5 R6
0017 0000 0055.1 0055 0003 01 40 04 04 00 04 00 00 00
TRACE COMMAND
IAR INST EADDR (EADDR) PSBU PSBL 00 R1 R2 R3 R4 R5 R6
0017 0000 0A 0004 01 40 04 04 00 04 00 00 00
TRACE COMMAND
IAR INST EADDR (EADDR) PSBU PSBL 00 R1 R2 R3 R4 R5 R6
0014 LCA+0 0061.3- 0061 0001 01 80 04 03 00 04 00 00 00
TRACE COMMAND
IAR INST EADDR (EADDR) PSBU PSBL 00 R1 R2 R3 R4 R5 R6
0017 0000 0055.1 0055 0003 01 40 04 03 00 04 00 00 00
TRACE COMMAND
IAR INST EADDR (EADDR) PSBU PSBL 00 R1 R2 R3 R4 R5 R6
0014 0000 0A 0004 01 40 04 03 00 04 00 00 00
TRACE COMMAND
IAR INST EADDR (EADDR) PSBU PSBL 00 R1 R2 R3 R4 R5 R6
0017 0000 0055.1 0055 0002 01 40 01 03 00 03 00 00 00
TRACE COMMAND
IAR INST EADDR (EADDR) PSBU PSBL 00 R1 R2 R3 R4 R5 R6
0017 0000 0A 0004 01 40 01 03 00 03 00 00 00
TRACE COMMAND
IAR INST EADDR (EADDR) PSBU PSBL 00 R1 R2 R3 R4 R5 R6
0014 LCA+0 0061.3- 0061 0004 01 80 03 01 00 03 00 00 00
TRACE COMMAND
IAR INST EADDR (EADDR) PSBU PSBL 00 R1 R2 R3 R4 R5 R6
0017 0000 0055.1 0055 0002 01 00 00 02 00 02 00 00 00
TRACE COMMAND
IAR INST EADDR (EADDR) PSBU PSBL 00 R1 R2 R3 R4 R5 R6
0014 0000 0A 0004 01 40 02 02 00 02 00 00 00
TRACE COMMAND
IAR INST EADDR (EADDR) PSBU PSBL 00 R1 R2 R3 R4 R5 R6
0017 0000 0055.1 0055 0001 01 80 03 01 00 03 00 00 00
TRACE COMMAND
IAR INST EADDR (EADDR) PSBU PSBL 00 R1 R2 R3 R4 R5 R6
0017 0000 0A 0004 01 40 02 01 00 01 00 00 00

```

Figure 18. FIRST COMMAND SET

TRAC#	COMMAND	INST	EAPOS	LEADER	PSBU	PSBL	R0	R1	R2	R3	R4	R5	R6
001A	CCMFD	CA	CCJB	000A	01	40	03	01	00	01	00	00	00
0050	17	27	15	48	65	03	01	02	02	05	05	04	03
0062	00	00	01	02	03	04	05	06	07	08	09	0A	0B
007D	40	40	40	40	40	40	40	40	40	40	40	40	40

NO. OF MACHINE CYCLES EXECUTED = 232

NO. OF INSTRUCTIONS EXECUTED = 23

Figure 19. FIRST COMMAND SET, Cont.

```

START 00
PATCH 55.0 51.1 57.2 50.2 55.3
PATCH 58.5 58.4 50.3 50.2 55.1
PATCH 54.0
PATCH 61.0
PATCH 62.0 63.0 64.1 65.1 66.1
PATCH 67.2 68.9 69.8 68.2 67.1
TIME 3.55.77
DUMP 0.55.77
TRACE 14.10
PATCH 33.0B
PATCH 12.0E
PAGE

```

```

COMMAND DUMP
0050 17 07 15 18 65 00 01 02 07 03 05 04 03 02 01 00
0100 00 00 00 00 01 01 03 02 09 08 02 01 03 00 00 00
0200 00 00 00 00 00 00 00 00 00 00 00 00 00 00 00 00
TRACE COMMAND
IAR INST EADDR (EADDR) PSBU PSBL 00 R1 R2 R3 R4 R5 R6
0014 LDA#0 0061.3,- E068 0001 01 08 00 00 00 00 00 00
TRACE COMMAND EADDR (EADDR) PSBU PSBL 00 R1 R2 R3 R4 R5 R6
IAR INST E06F 0000 01 48 01 00 00 00 00 00 00
0017 ACDA#0 0054.1 E068 0000 01 48 01 00 00 00 00 00
TRACE COMMAND EADDR (EADDR) PSBU PSBL 00 R1 R2 R3 R4 R5 R6
IAR INST E068 0004 01 48 01 00 00 00 00 00 00
0014 CCM#0 0A E068 0002 01 88 01 0A 00 0A 00 00 00
TRACE COMMAND EADDR (EADDR) PSBU PSBL 00 R1 R2 R3 R4 R5 R6
IAR INST E068 0001 01 48 01 00 00 00 00 00 00
0017 ACDA#0 0054.1 E068 0001 01 48 02 04 00 05 00 00 00
TRACE COMMAND EADDR (EADDR) PSBU PSBL 00 R1 R2 R3 R4 R5 R6
IAR INST E068 0004 01 48 03 0A 00 09 00 00 00 00
0014 CCM#0 0A E068 0004 01 48 03 0A 00 09 00 00 00
TRACE COMMAND EADDR (EADDR) PSBU PSBL 00 R1 R2 R3 R4 R5 R6
IAR INST E068 0008 01 48 03 09 00 09 00 00 00 00
0014 LDA#0 0061.3,- E068 0008 01 48 03 09 00 09 00 00 00
TRACE COMMAND EADDR (EADDR) PSBU PSBL 00 R1 R2 R3 R4 R5 R6
IAR INST E068 0008 01 48 03 09 00 09 00 00 00 00
0017 ACDA#0 0054.1 E068 0008 01 48 03 09 00 09 00 00 00
TRACE COMMAND EADDR (EADDR) PSBU PSBL 00 R1 R2 R3 R4 R5 R6
IAR INST E068 0008 01 48 03 09 00 09 00 00 00 00
0014 LDA#0 0061.3,- E068 0008 01 48 03 09 00 09 00 00 00
TRACE COMMAND EADDR (EADDR) PSBU PSBL 00 R1 R2 R3 R4 R5 R6
IAR INST E068 0008 01 48 03 09 00 09 00 00 00 00
0017 ACDA#0 0054.1 E068 0008 01 48 03 09 00 09 00 00 00

```

```

TRACE COMMAND EADDR (EADDR) PSBU PSBL 00 R1 R2 R3 R4 R5 R6
IAR INST E068 0008 01 48 03 09 00 09 00 00 00 00
0014 CCM#0 0A E068 0008 01 48 03 09 00 09 00 00 00
TRACE COMMAND EADDR (EADDR) PSBU PSBL 00 R1 R2 R3 R4 R5 R6
IAR INST E068 0008 01 48 03 09 00 09 00 00 00 00
0014 LDA#0 0061.3,- E068 0008 01 48 03 09 00 09 00 00 00
TRACE COMMAND EADDR (EADDR) PSBU PSBL 00 R1 R2 R3 R4 R5 R6
IAR INST E068 0008 01 48 03 09 00 09 00 00 00 00
0017 ACDA#0 0054.1 E068 0008 01 48 03 09 00 09 00 00 00
TRACE COMMAND EADDR (EADDR) PSBU PSBL 00 R1 R2 R3 R4 R5 R6
IAR INST E068 0008 01 48 03 09 00 09 00 00 00 00
0014 CCM#0 0A E068 0008 01 48 03 09 00 09 00 00 00
TRACE COMMAND EADDR (EADDR) PSBU PSBL 00 R1 R2 R3 R4 R5 R6
IAR INST E068 0008 01 48 03 09 00 09 00 00 00 00
0017 ACDA#0 0054.1 E068 0008 01 48 03 09 00 09 00 00 00
TRACE COMMAND EADDR (EADDR) PSBU PSBL 00 R1 R2 R3 R4 R5 R6
IAR INST E068 0008 01 48 03 09 00 09 00 00 00 00
0014 LDA#0 0061.3,- E068 0008 01 48 03 09 00 09 00 00 00
TRACE COMMAND EADDR (EADDR) PSBU PSBL 00 R1 R2 R3 R4 R5 R6
IAR INST E068 0008 01 48 03 09 00 09 00 00 00 00
0017 ACDA#0 0054.1 E068 0008 01 48 03 09 00 09 00 00 00
TRACE COMMAND EADDR (EADDR) PSBU PSBL 00 R1 R2 R3 R4 R5 R6
IAR INST E068 0008 01 48 03 09 00 09 00 00 00 00
0014 LDA#0 0061.3,- E068 0008 01 48 03 09 00 09 00 00 00
TRACE COMMAND EADDR (EADDR) PSBU PSBL 00 R1 R2 R3 R4 R5 R6
IAR INST E068 0008 01 48 03 09 00 09 00 00 00 00
0017 ACDA#0 0054.1 E068 0008 01 48 03 09 00 09 00 00 00

```

Figure 20. SECOND COMMAND SET

```

TRACE COMMAND
IAR INST
CC1A CCND 0A EADDR (EADDR) PSBU PSSL 00 R1 R2 R3 R4 R5 R6
CC1B 000A 01 98 01 02 00 01 00 00 00
TRACE COMMAND
IAR INST
CC14 CCND 0061,7,- EADDR (EADDR) PSBU PSSL 00 R1 R2 R3 R4 R5 R6
CC15 0000 01 88 07 01 00 01 00 00 00
TRACE COMMAND
IAR INST
CC17 CCND 0054+1 EADDR (EADDR) PSBU PSSL 00 R1 R2 R3 R4 R5 R6
CC18 0000 01 08 00 01 00 00 00 00 00
TRACE COMMAND
IAR INST
CC1A CCND 0A EADDR (EADDR) PSBU PSSL 00 R1 R2 R3 R4 R5 R6
CC1B 000A 01 08 00 01 00 00 00 00 00
COMMAND GROUP
0053 17 07 13 18 65 0C 01 02 03 04 05 06 07 08 09 0A 0B 0C 0D 0E 0F
0069 02 00 01 02 03 04 05 06 07 08 09 0A 0B 0C 0D 0E 0F 10 11 12 13
0070 40 40 40 40 40 40 40 40 40 40 40 40 40 40 40 40 40 40 40 40 40

```

NO. OF MACHINE CYCLES EXECUTED = 252

NO. OF INSTRUCTIONS EXECUTED = 79

Figure 21. SECOND COMMAND SET, Cont.



APPENDIXES

APPENDIX A

MEMORY INTERFACE

Figure 22 shows a complete interface between the 2650 and a 256 x 8 R/W random access memory. Since the memory chips are MOS they can be driven directly by the address lines and the control lines. The gates shown are assumed to be standard 7400 series TTL so that some signal buffering is assumed to be necessary. If CMOS or 74LS gates are used, some of the buffering inverters may not be necessary. The same is true of the data bus. Depending on the number and nature of the I/O devices being interfaced, it may or may not be necessary to buffer the data bus.

Because the data in and data out signals for the memory chips are bussed together, care must be taken to avoid overlap of drivers on the data bus. In this example, the problem is solved by using the write pulse into the memory as the chip select input instead of using the $\overline{R/W}$ line as is conventionally done. The $\overline{R/W}$ output from the processor is a level and is valid when Operation Request is true. Write Pulse from the processor is gated with the OPREQ and M/I \overline{O} signals to assure proper operation.

For a large memory the next address line (ADR8) could be gated into the chain that generates the chip select signals, with similar write pulse generation for the higher order memory.

The \overline{OPACK} signal is assumed to be false for the duration of all memory operations. This eliminates some gating from that control input. No problems will be encountered with this approach as long as the memories are fast enough for the clock speed being used with the processor. At a cycle time of 2.4 μ s, data must be returned to the processor by 1 μ s or less time from the OPREQ leading edge.

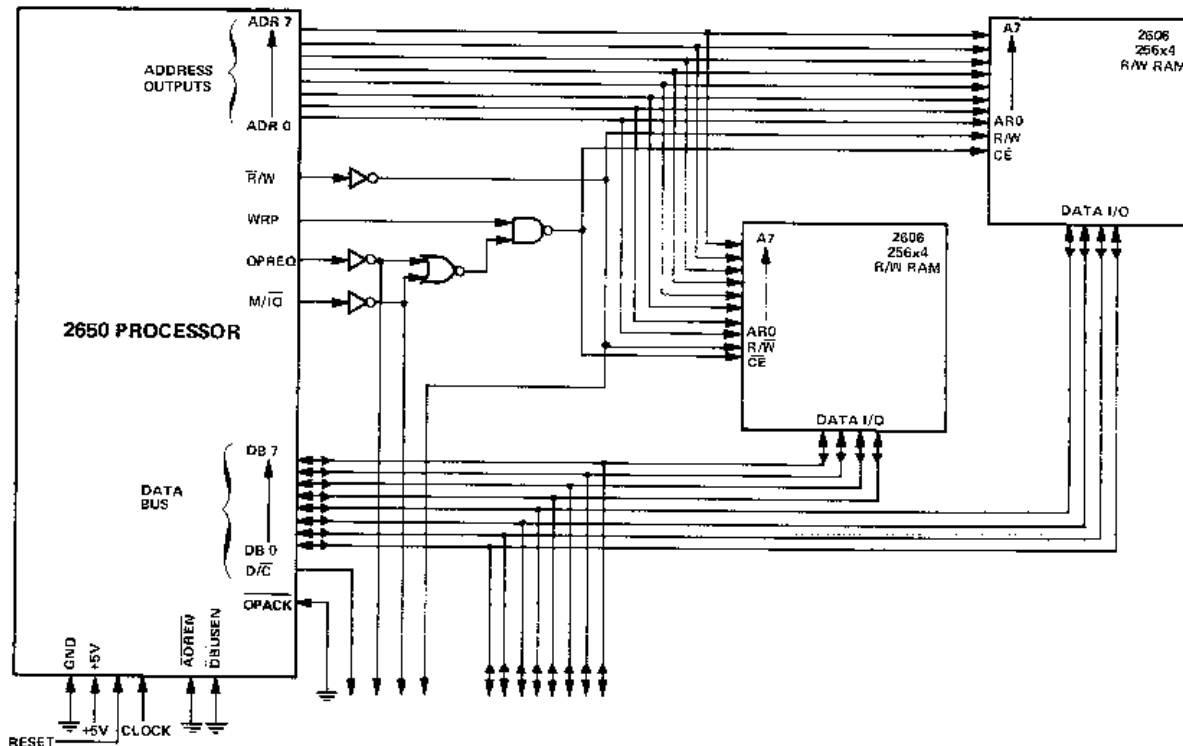

Figure 22.

APPENDIX B

I/O INTERFACE

Figure 23 shows one of many possible methods for buffering the data bus and interfacing it to several devices. There are advantages to be gained by using the Signetics 8T26. It has a PNP input buffer that keeps its low input level current at $200\mu\text{A}$ instead of 1.6mA . This lightens the load on the processor bus drivers and allows the processor to interface to several 8T26's if necessary. The 8T26 has four complete driver/receiver pairs in a package, so two packages can fully buffer the 8-bit data bus.

The control signals generated for use with I/O interfaces are very straightforward. Combining $M/\bar{I}\bar{O}$ with $OPREQ$ generates a signal that can often be used conveniently at the I/O devices instead of having each device derive the signal individually. In the figure it is gated with the Read/Write information in order to control the bus buffer.

Each I/O device must handle four basic processor interface functions:

- (a) bus interface
- (b) data transfer logic
- (c) device selection logic
- (d) transfer acknowledge logic

Depending on the nature of the complete system and the particular I/O device, these functions can be either extremely simple or fairly complex.

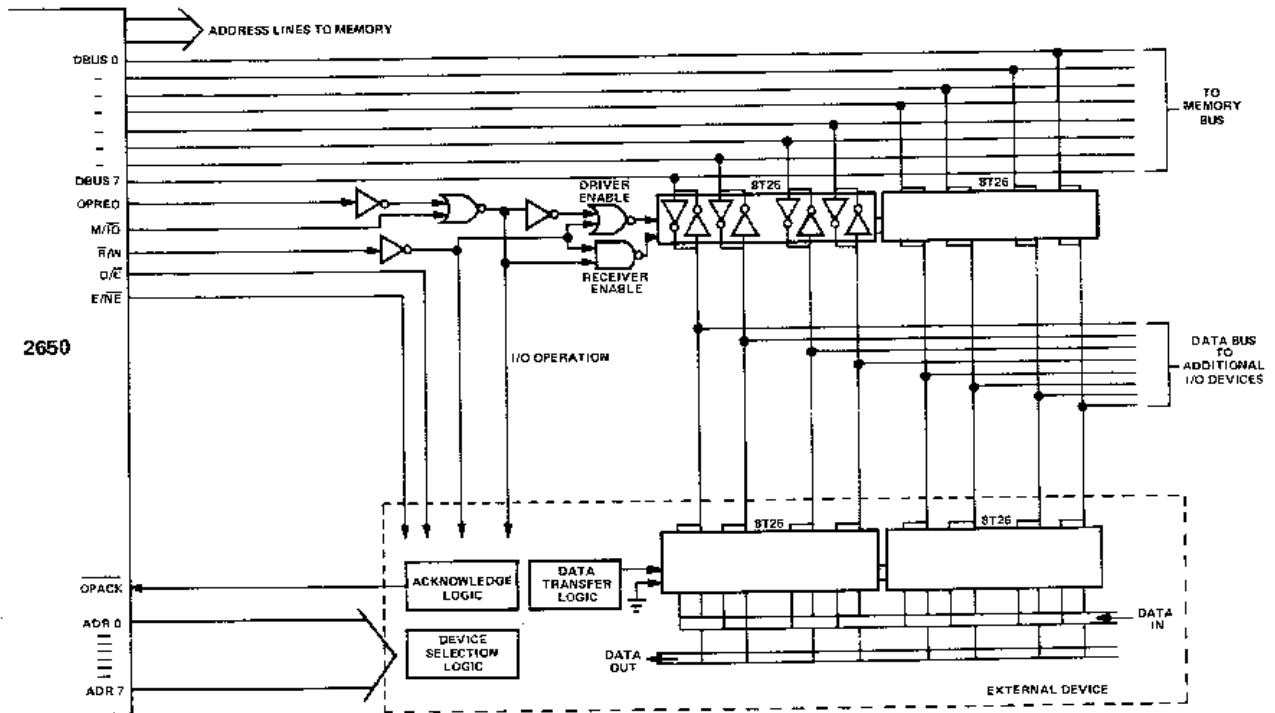

Figure 23.

APPENDIX C

INSTRUCTIONS, ADDITIONAL INFORMATION

The 2650 uses variable length instructions that are one, two or three bytes long. The instruction length is determined by the nature of the operation being performed and the addressing mode being used. Thus, the instruction can be expressed in one byte when no memory operand addressing is necessary, as with register-to-register or rotate instructions. On the other hand, for direct addressing instructions, three bytes are allocated. The relative and immediate addressing modes allow two-byte instructions to be implemented.

The 2650 uses explicit operand addressing; that is, each instruction specifies the operand address. The first byte of each 2650 instruction is divided into three fields and specifies the operation to be performed, the addressing mode to be used and, where appropriate, the register or condition code mask to be used.

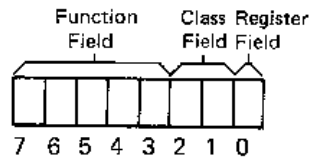

The CLASS field specifies the instruction group, the major address mode and the number of processor cycles required for each instruction. The CLASS field also specifies, with one exception, the number of bytes in the instruction. The following table shows the specifications for each class.

CLASS FIELD	INSTRUCTION GROUP	ADDRESS REGISTER	BYTE LENGTH	DIRECT CYCLES
0	Arithmetic	Register	1	2
1	Arithmetic	Immediate	2	2
2	Arithmetic	Relative	2	3
3	Arithmetic	Absolute	3	4
4	Control (inc. rotate)		1	2
5	Control		1-2	3
6	Branch	Relative	2	3
7	Branch	Absolute	3	3

Within the arithmetic groups (classes 0, 1, 2, and 3) the function field specifies one of the eight operations as follows:

FUNCTION FIELD	ARITHMETIC OPERATION
0	LOAD
1	EXCLUSIVE OR
2	AND
3	INCLUSIVE OR
4	ADD
5	SUBTRACT
6	STORE
7	COMPARE

Within the branch group (classes 6 and 7) the function field specifies one of eight operations as follows:

FUNCTION FIELD	BRANCH OPERATION
0	Branch On Condition True
1	Branch To Subroutine On Condition True
2	Branch On Register Non-Zero
3	Branch To Subroutine On Register Non-Zero
4	Branch On Condition False
5	Branch To Subroutine On Condition False
6	Branch On Incrementing Register
7	Branch On Decrementing Register

There is very little pattern to the use of the function field within the control group (classes 4 and 5).

The register field is used to specify the index register, to specify the operand source register, to specify the destination register, or a condition code mask. For the register-to-register and the indexed instructions, register zero is implicitly assumed to be the source or the destination of the instruction. For all other instructions that involve a register, the register field allows any of four registers to be specified, except for indexed branch instructions which require that register 3 be specified.

Conditional branch instructions utilize the 2-bit register field as a condition code mask field. A few instructions use the register field as part of the operation code and consequently allow no variation in register usage.

APPENDIX D

INSTRUCTION SUMMARY

SIGNETICS 2650 PROCESSOR

ALPHABETIC LISTING

HEX	OP	Pg.	HEX	OP	Pg.	HEX	OP	Pg.
8C	ADDA	57	98	BCFR	75	BC	BSFA	81
8D			99			BD		
8E			9A			BE		
8F								
84	ADDI	56	1C	BCTA	74	B8	BSFR	81
85			1D			B9		
86			1E			BA		
87			1F					
88	ADDR	56	18	BCTR	74	7C	BSNA	82
89			19			7D		
8A			1A			7E		
8B			1B			7F		
80	ADDZ	55	FC	BDRA	77	78	BSNR	82
81			FD			79		
82			FE			7A		
83			FF			7B		
4C	ANDA	61	F8	BDRR	77	3C	BSTA	80
4D			F9			3D		
4E			FA			3E		
4F			FB			3F		
44	ANDI	60	DC	BIRA	76	38	BSTR	80
45			DD			39		
46			DE			3A		
47			DF			3B		
48	ANDR	60	D8	BIRR	76	BF	BSXA	83
49			D9					
4A			DA					
4B			DB					
41	ANDZ	59	5C	BRNA	78	9F	BXA	79
42			5D					
43			5E					
			5F					
9C	BCFA	75	58	BRNR	78	EC	C MA	67
9D			59			ED		
9E			5A			EE		
			5B			EF		

HEX	OP	Pg.	HEX	OP	Pg.	HEX	OP	Pg.
E4	CØMI	66	40	HALT	90	93	LPSL	69
E5								
E6						92	LPSU	68
E7								
E8	CØMR	66	6C	LØRA	63	C0	NØP	87
E9			6D					
EA			6E					
EB			6F					
E0	CØMZ	65	64	LØRI	62	77	PPSL	71
E1			65					
E2			66			76	PPSU	70
E3			67					
75	CPSL	72	68	LØRR	62	30	REDC	85
74	CPSU	71	69			31		
			6A			32		
			6B			33		
94	DAR	89	60	LØRZ	61	70	REDD	84
95			61			71		
96			62			72		
97			63			73		
2C	EØRA	65	0C	LØDA	53	54	REDE	85
2D			0D			55		
2E			0E			56		
2F			0F			57		
24	EØRI	64	04	LØDI	52	14	RETC	83
25			05			15		
26			06			16		
27			07			17		
28	EØRR	64	08	LØDR	53	34	RETE	84
29			09			35		
2A			0A			36		
2B			0B			37		
20	EØRZ	63	00	LØDZ	52	D0	RRL	67
21			01			D1		
22			02			D2		
23			03			D3		

HEX	OP	Pg.	HEX	OP	Pg.
50	RRR	68	F4	TMI	88
51			F5		
52			F6		
53			F7		
13	SPSL	70	B5	TPSL	73
12	SPSU	69	B4	TPSU	72
CC	STRA	55	B0	WRTC	86
CD			B1		
CE			B2		
CF			B3		
C8	STRR	54	F0	WRTD	86
C9			F1		
CA			F2		
CB			F3		
C1	STRZ	54	D4	WRTE	87
C2			D5		
C3			D6		
AC	SUBA	59	D7		
AD			9B	ZBRR	73
AE			BB	ZBSR	79
AF					
A4	SUBI	58			
A5					
A6					
A7					
A8	SUBR	58			
A9					
AA					
AB					
A0	SUBZ	57			
A1					
A2					
A3					

SIGNETICS 2650 PROCESSOR

NUMERIC LISTING

HEX	OP	Pg.	HEX	OP	Pg.	HEX	OP	Pg.
00	LØDZ	52	24	EØRI	64	44	ANDI	60
01			25			45		
02			26			46		
03			27			47		
04	LØDI	52	28	EØRR	64	48	ANDR	60
05			29			49		
06			2A			4A		
07			2B			4B		
08	LØDR	53	2C	EØRA	65	4C	ANDA	61
09			2D			4D		
0A			2E			4E		
0B			2F			4F		
0C	LØDA	53	30	REDC	85	50	RRR	68
0D			31			51		
0E			32			52		
0F			33			53		
12	SPSU	69	34	RETE	84	54	REDE	85
13	SPSL	70	35			55		
14	RETC	83	36			56		
15			37			57		
16			38	BSTR	80	58	BRNR	78
17			39			59		
18	BCTR	74	3A			5A		
19			3B			5B		
1A			3C	BSTA	80	5C	BRNA	78
1B			3D			5D		
1C	BCTA	74	3E			5E		
1D			3F			5F		
1E			40	HALT	90	60	IØRZ	61
1F						61		
20	EØRZ	63				62		
21						63		
22			41	ANDZ	59	64	IØRI	62
23			42			65		
			43			66		
						67		

HEX	OP	Pg.	HEX	OP	Pg.	HEX	OP	Pg.
68	IORR	62	88	ADDR	56	A4	SUBI	58
69			89			A5		
6A			8A			A6		
6B			8B			A7		
6C	IORA	63	8C	ADDA	57	A8	SUBR	58
6D			8D			A9		
6E			8E			AA		
6F			8F			AB		
70	REDD	84	92	LPSU	68	AC	SUBA	59
71						AD		
72			93	LPSL	69	AE		
73						AF		
74	CPSU	71	94	DAR	89	B0	WRTC	86
75	CPSL	72	95			B1		
76	PPSU	70	96			B2		
77	PPSL	71	97			B3		
78	BSNR	82	98	BCFR	75	B4	TPSU	72
79			99			B5	TPSL	73
7A			9A			B8	BSFR	81
7B			9B	ZBRR	73	B9		
7C	BSNA	82				BA		
7D			9C	BCFA	75	BB	ZBSR	79
7E			9D					
7F			9E					
80	ADDZ	55	9F	BXA	79	BC	BSFA	81
81						BD		
82						BE		
83								
84	ADDI	56	A0	SUBZ	57	BF	BSXA	83
85			A1					
86			A2					
87			A3					

HEX	OP	Pg.	HEX	OP	Pg.
C0	NØP	87	E4	CØMI	66
			E5		
			E6		
			E7		
C1	STRZ	54	E8	CØMR	66
C2			E9		
C3			EA		
			EB		
C8	STRR	54	EC	CØMA	67
C9			ED		
CA			EE		
CB			EF		
CC	STRA	55	F0	WRTD	86
CD			F1		
CE			F2		
CF			F3		
D0	RRL	67	F4	TMI	88
D1			F5		
D2			F6		
D3			F7		
D4	WRTE	87	F8	BDRR	77
D5			F9		
D6			FA		
D7			FB		
D8	BIRR	76	FC	BDRA	77
D9			FD		
DA			FE		
DB			FF		
DC	BIRA	76			
DD					
DE					
DF					
E0	CØMZ	65			
E1					
E2					
E3					

2650 INSTRUCTIONS

ORGANIZED BY FUNCTION

LOAD/STORE	Pg.	ARITHMETIC	Pg.	ARITHMETIC	Pg.
00 LØDZ	52	80 ADDZ	55	68 IØRR	62
01		81		69	
02		82		6A	
03		83		6B	
04 LØDI	52	84 ADDI	56	6C IØRA	63
05		85		6D	
06		86		6E	
07		87		6F	
08 LØDR	53	88 ADDR	56	20 EØRZ	63
09		89		21	
0A		8A		22	
0B		8B		23	
0C LØDA	53	8C ADDA	57	24 EØRI	64
0D		8D		25	
0E		8E		26	
0F		8F		27	
C1 STRZ	54	A0 SUBZ	57	28 EØRR	64
C2		A1		29	
C3		A2		2A	
		A3		2B	
C8 STRR	54	A4 SUBI	58	2C EØRA	65
C9		A5		2D	
CA		A6		2E	
CB		A7		2F	
CC STRA	55	A8 SUBR	58	41 ANDZ	59
CD		A9		42	
CE		AA		43	
CF		AB			
		AC SUBA	59	44 ANDI	60
		AD		45	
		AE		46	
		AF		47	
		60 IØRZ	61	48 ANDR	60
		61		49	
		62		4A	
		63		4B	
		64 IØRI	62	4C ANDA	61
		65		4D	
		66		4E	
		67		4F	

BRANCH		Pg.	SUBROUTINE BRANCH		Pg.	COMPARE		Pg.
18	BCTR	74	38	BSTR	80	E0	CØMZ	65
19			39			E1		
1A			3A			E2		
1B			3B			E3		
1C	BCTA	74	3C	BSTA	80	E4	CØMI	66
1D			3D			E5		
1E			3E			E6		
1F			3F			E7		
98	BCFR	75	B8	BSFR	81	E8	CØMR	66
99			B9			E9		
9A			BA			EA		
						EB		
9C	BCFA	75	BC	BSFA	81	EC	CØMA	67
9D			BD			ED		
9E			BE			EE		
						EF		
58	BRNR	78	78	BSNR	82	INPUT/OUTPUT		
59			79			30	REDC	85
5A			7A			31		
5B			7B			32		
5C	BRNA	78	7C	BSNA	82	33		
5D			7D			70	REDD	84
5E			7E			71		
5F			7F			72		
D8	BIRR	76	BF	BSXA	83	73		
D9						B0	WRTC	86
DA						B1		
DB						B2		
DC	BIRA	76	BB	ZBSR	79	B3		
DD						F0	WRTD	86
DE						F1		
DF						F2		
F8	BDRR	77	SUBROUTINE RETURN			F3		
F9			14	RETC	83	54	REDE	85
FA			15			55		
FB			16			56		
FC	BDRA	77	17			57		
FD			34	RETE	84	D4	WRTE	87
FE			35			D5		
FF			36			D6		
9F	BXA	79	37			D7		
98	ZBRR	73						

PROGRAM STATUS

MANIPULATION	Pg.	MISCELLANEOUS	Pg.
92 LPSU	68	C0 NOP	87
93 LPSL	69		
12 SPSU	69	40 HALT	90
13 SPSL	70		
74 CPSU	71	F4 TMI	88
75 CPSL	72	F5	
76 PPSU	70	F6	
77 PPSL	71	F7	
B4 TPSU	72	94 DAR	89
B5 TPSL	73	95	
		96	
		97	

ROTATE INSTRUCTIONS

D0 RRL	67
D1	
D2	
D3	
50 RRR	68
51	
52	
53	

APPENDIX E

SUMMARY OF 2650 INSTRUCTION MNEMONICS

In these tables parentheses are used to indicate options. In no case are they coded in any instruction. The following abbreviations are used:

- r — register expression, must evaluate to $0 \leq r \leq 3$.
- v — value expression
- * — indirect indicator
- a — address expression
- x — index register expression
- X — index register expression with optional auto-increment or auto-decrement

NOTE:

- the use of the indirect indicator is always optional.
- when an index register expression is specified, it can be followed by ', +' or ', -' which indicates use of auto-increment or auto-decrement of the index register. Example:

LODA, 0 DPR, R3, +

- BXA, BSXA are exceptions and do not permit auto-increment or auto-decrement. even though an address expression is specified in a hardware relative addressing instruction, the assembler develops it into a value of $(-64 \leq V \leq +63)$.
- a memory reference instruction which requires indexing may use only register 0 as the destination of the operation.
- if an index register expression is used with either the BXA or BSXA instructions it must specify index register #3 (either register bank) for indexing. Any other value in the index field will produce an error during assembly. However, it is not necessary to use an index register expression with these instructions; a blank in this field will default to register 3.

LOAD/STORE INSTRUCTIONS		Length (bytes)				
LODZ	r	Load Register Zero	1	BIRA,r	(*a) Branch on Incrementing Register Absolute	3
LODL,r	v	Load Immediate	2	BDRR,r	(*a) Branch on Decrementing Register Relative	2
LODR,r	(*a)	Load Relative	2	BDRR,r	(*a) Branch on Decrementing Register Absolute	3
LODA,r	(*a),(X)	Load Absolute	3	BXA	(*a),(x) Branch Indexed Absolute, Unconditional	3
STRZ	r	Store Register Zero	1	ZBRR	(*a) Zero Branch Relative, Unconditional	2
STRR,r	(*a)	Store Relative	2			
STRA,r	(*a),(X)	Store Absolute	3			
ARITHMETIC INSTRUCTIONS						
ADJZ	r	Add to Register Zero	1			
ADDI,r	v	Add Immediate	2			
ADDR,r	(*a)	Add Relative	2			
ADDA,r	(*a),(X)	Add Absolute	3			
SUBZ	r	Subtract from Register Zero	1			
SUBI,r	v	Subtract Immediate	2			
SUBR,r	(*a)	Subtract Relative	2			
SUBA,r	(*a),(X)	Subtract Absolute	3			
LOGICAL INSTRUCTIONS						
ANDZ	r	And to Register Zero	1			
ANDI,r	v	And Immediate	2			
ANDR,r	(*a)	And Relative	2			
ANDA,r	(*a),(X)	And Absolute	3			
IORZ	r	Inclusive or to Register Zero	1			
IORL,r	v	Inclusive or Immediate	2			
IORR,r	(*a)	Inclusive or Relative	2			
IORA,r	(*a),(X)	Inclusive or Absolute	3			
EORZ	r	Exclusive or to Register Zero	1			
EORL,r	v	Exclusive or Immediate	2			
EORR,r	(*a)	Exclusive or Relative	2			
EORA,r	(*a),(X)	Exclusive or Absolute	3			
COMPARISON INSTRUCTIONS						
COMZ	r	Compare to Register Zero	1			
COMI,r	v	Compare Immediate	2			
COMR,r	(*a)	Compare Relative	2			
COMA,r	(*a),(X)	Compare Absolute	3			
ROTATE INSTRUCTIONS						
RRR,r		Rotate Register Right	1			
RRL,r		Rotate Register Left	1			
BRANCH INSTRUCTIONS						
BCTR,v	(*a)	Branch on Condition True Relative	2			
BCFR,v	(*a)	Branch on Condition False Relative	2			
BCTA,v	(*a)	Branch on Condition True Absolute	3			
BCFA,v	(*a)	Branch on Condition False Absolute	3			
BRNR,r	(*a)	Branch on Register Non-Zero Relative	2			
BRNA,r	(*a)	Branch on Register Non-Zero Absolute	3			
BIRR,r	(*a)	Branch on Incrementing Register Relative	2			
SUBROUTINE BRANCH/RETURN INSTRUCTIONS						
BSTR,v	(*a)	Branch to Subroutine on Condition True, Relative	2			
BBSR,v	(*a)	Branch to Subroutine on Condition False, Relative	2			
BSTA,v	(*a)	Branch to Subroutine on Condition True, Absolute	3			
BSFA,v	(*a)	Branch to Subroutine on Condition False, Absolute	3			
BSSR,r	(*a)	Branch to Subroutine on Non-Zero Register, Relative	2			
BSNA,r	(*a)	Branch to Subroutine on Non-Zero Register, Absolute	3			
BSXA	(*a),(x)	Branch to Subroutine, Indexed, Unconditional	3			
RETC,v		Return From Subroutine, Conditional	1			
RETE,v		Return From Subroutine and Enable Interrupt, Conditional	1			
ZBSR	(*),a	Zero Branch to Subroutine Relative, Unconditional	2			
PROGRAM STATUS INSTRUCTIONS						
LPSU		Load Program Status, Upper	1			
LPSL		Load Program Status, Lower	1			
SPSU		Store Program Status, Upper	1			
SPSL		Store Program Status, Lower	1			
CPSU	v	Clear Program Status, Upper, Selective	2			
CPSL	v	Clear Program Status, Lower, Selective	2			
PPSU	v	Preset Program Status, Upper, Selective	2			
PPSL	v	Preset Program Status, Lower, Selective	2			
TPSU	v	Test Program Status, Upper, Selective	2			
TPSL	v	Test Program Status Lower, Selective	2			
INPUT/OUTPUT INSTRUCTIONS						
WRD,r		Write Data	1			
REDD,r		Read Data	1			
WRTC,r		Write Control	1			
REDC,r		Read Control	1			
WRTE,r	v	Write Extended	2			
REDE,r	v	Read Extended	2			
MISCELLANEOUS INSTRUCTIONS						
HALT		Halt, Enter Wait State	1			
DAR,r		Decimal Adjust Register	1			
TML,r	v	Test Under Mask Immediate	2			
NO		No Operation	1			

APPENDIX F

NOTES ABOUT THE 2650 PROCESSOR

1. AUTO-INCREMENT, DECREMENT of index register. This feature is optional on any instruction which uses indexing with the exception of BXA and BSXA. The increment or decrement occurs before the index register is added to the displacement in the instruction.
2. The contents of registers when used for indexing are considered to be unsigned absolute numbers. Consequently, index registers can contain values from 0 to 255. They "wrap-around" so that the number following 255 is 0.
3. Only absolute addressing instructions can be indexed.
4. The Branch on Incrementing Register or Decrementing Register instructions perform the increment or decrement before testing for zero. The only time the branch address is not taken, is when the register contains zero.
5. All hardware relative addressing is implemented as modulo 8K and therefore relative addressing across the top of a page boundary will result in a physical address near the bottom of the page being accessed. For example:

1FFC₁₆ LODR,R2 \$+16

This instruction results, during execution, in accessing the byte at location 000C in the same page as the instruction. Similarly, negative relative addresses from near the bottom of a page may result in an effective address near the top of the page.

6. Page boundaries cannot be indexed across.
7. Data can always be accessed across a page boundary through use of relative indirect or absolute indirect addressing modes.
8. The only way to transfer control to a program in some other page is to branch absolute or branch indirectly to the new page. Program execution cannot flow across a page boundary.
9. Unconditional branch or branch to subroutine instructions are coded by specifying a value of 3 in the register/value field of BSTA, BSTR, BCTA or BCTR. Example:

```
UN                      EQU                      3
                          •••
                          •••
                          •••
                          BSTA,UN            PAL
                          BCTR,3            LOOP
```

Unconditional branches on conditions false (BCFA, BCFR) are not allowed.

APPENDIX G

ASC II AND EBCDIC CODES

This table presents the only characters that the assembler will recognize in an A or E type constant and their equivalent codes in hexadecimal.

VALID CHARACTERS	EBCDIC CODE	ASC II CODE	VALID CHARACTERS	EBCDIC CODE	ASC II CODE
0	F0	30	V	E5	56
1	F1	31	W	E6	57
2	F2	32	X	E7	58
3	F3	33	Y	E8	59
4	F4	34	Z	E9	5A
5	F5	35	blank	40	20
6	F6	36	.	4B	2E
7	F7	37	(4D	28
8	F8	38	+	4E	2B
9	F9	39		4F	7C
A	C1	41	&	50	26
B	C2	42	!	5A	21
C	C3	43	\$	5B	24
D	C4	44	*	5C	2A
E	C5	45)	5D	29
F	C6	46	;	5E	3B
G	C7	47	— or ~	5F	7E*
H	C8	48	-	60	2D
I	C9	49	/	61	2F
J	D1	4A	,	6B	2C
K	D2	4B	%	6C	25
L	D3	4C	— or ←	6D	5F*
M	D4	4D	>	6E	3E
N	D5	4E	?	6F	3F
O	D6	4F	:	7A	3A
P	D7	50	#	7B	23
Q	D8	51	@	7C	40
R	D9	52	'	7D	27
S	E2	53	=	7E	3D
T	E3	54	"	7F	22
U	E4	55	<	4C	3C

*may have different graphic symbols on different computer systems

APPENDIX H

COMPLETE ASCII CHARACTER SET

(MSB) b ₇				0	0	1	1	1	1	
b ₆			b ₅	1	1	0	0	1	1	
b ₄	b ₃		b ₂	b ₁	0	1	0	1	0	1
0	0	0	0	0	SP	0	@	P	'	p
0	0	0	1	0	!	1	A	Q	a	q
0	0	1	0	0	"	2	B	R	b	r
0	0	1	1	0	#	3	C	S	c	s
0	1	0	0	0	\$	4	D	T	d	t
0	1	0	1	0	%	5	E	U	e	u
0	1	1	0	0	&	6	F	V	f	v
0	1	1	1	0	'	7	G	W	g	w
1	0	0	0	0	{	8	H	X	h	x
1	0	0	1	0	}	9	I	Y	i	y
1	0	1	0	0	*	:	J	Z	j	z
1	0	1	1	0	+	;	K	[k	{
1	1	0	0	0	,	<	L	\	l	
1	1	0	1	0	-	=	M]	m	}
1	1	1	0	0	.	>	N	↑	n	~
1	1	1	1	0	/	?	O	←	o	DEL

APPENDIX I

POWERS OF TWO TABLE

2^n	n	2^{-n}
1	0	1.0
2	1	0.5
4	2	0.25
8	3	0.125
16	4	0.062 5
32	5	0.031 25
64	6	0.015 625
128	7	0.007 812 5
256	8	0.003 906 25
512	9	0.001 953 125
1 024	10	0.000 976 562 5
2 048	11	0.000 488 281 25
4 096	12	0.000 244 140 625
8 192	13	0.000 122 070 312 5
16 384	14	0.000 061 035 156 25
32 768	15	0.000 030 517 578 125
65 536	16	0.000 015 258 789 062 5
131 072	17	0.000 007 629 394 531 25
262 144	18	0.000 003 814 697 265 625
524 288	19	0.000 001 907 348 632 812 5
1 048 576	20	0.000 000 953 674 316 406 25
2 097 152	21	0.000 000 476 837 158 203 125
4 194 304	22	0.000 000 238 418 579 101 562 5
8 388 608	23	0.000 000 119 209 289 550 781 25
16 777 216	24	0.000 000 059 604 644 775 390 625
33 554 432	25	0.000 000 029 802 322 387 695 312 5
67 108 864	26	0.000 000 014 901 161 193 847 656 25
134 217 728	27	0.000 000 007 450 580 596 923 828 125
268 435 456	28	0.000 000 003 725 290 298 461 914 062 5
536 870 912	29	0.000 000 001 862 645 149 230 957 031 45
1 073 741 824	30	0.000 000 000 931 322 574 615 478 515 625
2 147 483 648	31	0.000 000 000 465 661 287 307 739 257 812 5
4 294 967 296	32	0.000 000 000 232 830 643 653 869 628 906 25
8 589 934 592	33	0.000 000 000 116 415 321 826 934 814 453 125
17 179 869 184	34	0.000 000 000 058 207 660 913 467 407 226 562 5
34 359 738 368	35	0.000 000 000 029 103 830 456 733 703 613 281 25
68 719 476 736	36	0.000 000 000 014 551 915 228 366 851 806 640 625
137 438 953 472	37	0.000 000 000 007 275 957 614 183 425 903 320 312 5
274 877 906 944	38	0.000 000 000 003 637 978 807 091 712 951 660 156 25
549 755 813 888	39	0.000 000 000 001 818 989 403 545 856 475 830 078 125
1 099 511 627 776	40	0.000 000 000 000 909 494 701 772 928 237 915 039 062 5

APPENDIX J

HEXADECIMAL-DECIMAL CONVERSION TABLES

From hex: locate each hex digit in its corresponding column position and note the decimal equivalents. Add these to obtain the decimal value.

From decimal: (1) locate the largest decimal value in the table that will fit into the decimal number to be converted, and (2) note its hex equivalent and hex column position. (3) Find the decimal remainder. Repeat the process on this and subsequent remainders.

Note: Decimal, hexadecimal, (and binary) equivalents of all numbers from 0 to 255 are listed on panels 9 - 12.

HEXADECIMAL COLUMNS											
6		5		4		3		2		1	
HEX = DEC		HEX = DEC		HEX = DEC		HEX = DEC		HEX = DEC		HEX = DEC	
0	0	0	0	0	0	0	0	0	0	0	0
1	1,048,576	1	65,536	1	4,096	1	256	1	16	1	1
2	2,097,152	2	131,072	2	8,192	2	512	2	32	2	2
3	3,145,728	3	196,608	3	12,288	3	768	3	48	3	3
4	4,194,304	4	262,144	4	16,384	4	1,024	4	64	4	4
5	5,242,880	5	327,680	5	20,480	5	1,280	5	80	5	5
6	6,291,456	6	393,216	6	24,576	6	1,536	6	96	6	6
7	7,340,032	7	458,752	7	28,672	7	1,792	7	112	7	7
8	8,388,608	8	524,288	8	32,768	8	2,048	8	128	8	8
9	9,437,184	9	589,824	9	36,864	9	2,304	9	144	9	9
A	10,485,760	A	655,360	A	40,960	A	2,560	A	160	A	10
B	11,534,336	B	720,896	B	45,056	B	2,816	B	176	B	11
C	12,582,912	C	786,432	C	49,152	C	3,072	C	192	C	12
D	13,631,488	D	851,968	D	53,248	D	3,328	D	208	D	13
E	14,680,064	E	917,504	E	57,344	E	3,584	E	224	E	14
F	15,728,640	F	983,040	F	61,440	F	3,840	F	240	F	15
0 1 2 3		4 5 6 7		0 1 2 3		4 5 6 7		0 1 2 3		4 5 6 7	
BYTE				BYTE				BYTE			

The table provides for direct conversion of hexadecimal and decimal numbers in these ranges:

Hexadecimal	Decimal
000 to FFF	0000 to 4095

In the table, the decimal value appears at the intersection of the row representing the most significant hexadecimal digits (16^2 and 16^1) and the column representing the least significant hexadecimal digit (16^0).

Example:

$C21_{16}$	=	3105_{10}	
HEX	0	1	2
C0	3072	3073	3074
C1	3088	3089	3090
C2	3104	3105	3106
C3	3120	3121	3122

APPENDIX J Cont'd.

	0	1	2	3	4	5	6	7	8	9	A	B	C	D	E	F
00	0000	0001	0002	0003	0004	0005	0006	0007	0008	0009	0010	0011	0012	0013	0014	0015
01	0016	0017	0018	0019	0020	0021	0022	0023	0024	0025	0026	0027	0028	0029	0030	0031
02	0032	0033	0034	0035	0036	0037	0038	0039	0040	0041	0042	0043	0044	0045	0046	0047
03	0048	0049	0050	0051	0052	0053	0054	0055	0056	0057	0058	0059	0060	0061	0062	0063
04	0064	0065	0066	0067	0068	0069	0070	0071	0072	0073	0074	0075	0076	0077	0078	0079
05	0080	0081	0082	0083	0084	0085	0086	0087	0088	0089	0090	0091	0092	0093	0094	0095
06	0096	0097	0098	0099	0100	0101	0102	0103	0104	0105	0106	0107	0108	0109	0110	0111
07	0112	0113	0114	0115	0116	0117	0118	0119	0120	0121	0122	0123	0124	0125	0126	0127
08	0128	0129	0130	0131	0132	0133	0134	0135	0136	0137	0138	0139	0140	0141	0142	0143
09	0144	0145	0146	0147	0148	0149	0150	0151	0152	0153	0154	0155	0156	0157	0158	0159
0A	0160	0161	0162	0163	0164	0165	0166	0167	0168	0169	0170	0171	0172	0173	0174	0175
0B	0176	0177	0178	0179	0180	0181	0182	0183	0184	0185	0186	0187	0188	0189	0190	0191
0C	0192	0193	0194	0195	0196	0197	0198	0199	0200	0201	0202	0203	0204	0205	0206	0207
0D	0208	0209	0210	0211	0212	0213	0214	0215	0216	0217	0218	0219	0220	0221	0222	0223
0E	0224	0225	0226	0227	0228	0229	0230	0231	0232	0233	0234	0235	0236	0237	0238	0239
0F	0240	0241	0242	0243	0244	0245	0246	0247	0248	0249	0250	0251	0252	0253	0254	0255

	0	1	2	3	4	5	6	7	8	9	A	B	C	D	E	F
10	0256	0257	0258	0259	0260	0261	0262	0263	0264	0265	0266	0267	0268	0269	0270	0271
11	0272	0273	0274	0275	0276	0277	0278	0279	0280	0281	0282	0283	0284	0285	0286	0287
12	0288	0289	0290	0291	0292	0293	0294	0295	0296	0297	0298	0299	0300	0301	0302	0303
13	0304	0305	0306	0307	0308	0309	0310	0311	0312	0313	0314	0315	0316	0317	0318	0319
14	0320	0321	0322	0323	0324	0325	0326	0327	0328	0329	0330	0331	0332	0333	0334	0335
15	0336	0337	0338	0339	0340	0341	0342	0343	0344	0345	0346	0347	0348	0349	0350	0351
16	0352	0353	0354	0355	0356	0357	0358	0359	0360	0361	0362	0363	0364	0365	0366	0367
17	0368	0369	0370	0371	0372	0373	0374	0375	0376	0377	0378	0379	0380	0381	0382	0383
18	0384	0385	0386	0387	0388	0389	0390	0391	0392	0393	0394	0395	0396	0397	0398	0399
19	0400	0401	0402	0403	0404	0405	0406	0407	0408	0409	0410	0411	0412	0413	0414	0415
1A	0416	0417	0418	0419	0420	0421	0422	0423	0424	0425	0426	0427	0428	0429	0430	0431
1B	0432	0433	0434	0435	0436	0437	0438	0439	0440	0441	0442	0443	0444	0445	0446	0447
1C	0448	0449	0450	0451	0452	0453	0454	0455	0456	0457	0458	0459	0460	0461	0462	0463
1D	0464	0465	0466	0467	0468	0469	0470	0471	0472	0473	0474	0475	0476	0477	0478	0479
1E	0480	0481	0482	0483	0484	0485	0486	0487	0488	0489	0490	0491	0492	0493	0494	0495
1F	0496	0497	0498	0499	0500	0501	0502	0503	0504	0505	0506	0507	0508	0509	0510	0511

	0	1	2	3	4	5	6	7	8	9	A	B	C	D	E	F
20	0512	0513	0514	0515	0516	0517	0518	0519	0520	0521	0522	0523	0524	0525	0526	0527
21	0528	0529	0530	0531	0532	0533	0534	0535	0536	0537	0538	0539	0540	0541	0542	0543
22	0544	0545	0546	0547	0548	0549	0550	0551	0552	0553	0554	0555	0556	0557	0558	0559
23	0560	0561	0562	0563	0564	0565	0566	0567	0568	0569	0570	0571	0572	0573	0574	0575
24	0576	0577	0578	0579	0580	0581	0582	0583	0584	0585	0586	0587	0588	0589	0590	0591
25	0592	0593	0594	0595	0596	0597	0598	0599	0600	0601	0602	0603	0604	0605	0606	0607
26	0608	0609	0610	0611	0612	0613	0614	0615	0616	0617	0618	0619	0620	0621	0622	0623
27	0624	0625	0626	0627	0628	0629	0630	0631	0632	0633	0634	0635	0636	0637	0638	0639
28	0640	0641	0642	0643	0644	0645	0646	0647	0648	0649	0650	0651	0652	0653	0654	0655
29	0656	0657	0658	0659	0660	0661	0662	0663	0664	0665	0666	0667	0668	0669	0670	0671
2A	0672	0673	0674	0675	0676	0677	0678	0679	0680	0681	0682	0683	0684	0685	0686	0687
2B	0688	0689	0690	0691	0692	0693	0694	0695	0696	0697	0698	0699	0700	0701	0702	0703
2C	0704	0705	0706	0707	0708	0709	0710	0711	0712	0713	0714	0715	0716	0717	0718	0719
2D	0720	0721	0722	0723	0724	0725	0726	0727	0728	0729	0730	0731	0732	0733	0734	0735
2E	0736	0737	0738	0739	0740	0741	0742	0743	0744	0745	0746	0747	0748	0749	0750	0751
2F	0752	0753	0754	0755	0756	0757	0758	0759	0760	0761	0762	0763	0764	0765	0766	0767

	0	1	2	3	4	5	6	7	8	9	A	B	C	D	E	F
30	0768	0769	0770	0771	0772	0773	0774	0775	0776	0777	0778	0779	0780	0781	0782	0783
31	0784	0785	0786	0787	0788	0789	0790	0791	0792	0793	0794	0795	0796	0797	0798	0799
32	0800	0801	0802	0803	0804	0805	0806	0807	0808	0809	0810	0811	0812	0813	0814	0815
33	0816	0817	0818	0819	0820	0821	0822	0823	0824	0825	0826	0827	0828	0829	0830	0831
34	0832	0833	0834	0835	0836	0837	0838	0839	0840	0841	0842	0843	0844	0845	0846	0847
35	0848	0849	0850	0851	0852	0853	0854	0855	0856	0857	0858	0859	0860	0861	0862	0863
36	0864	0865	0866	0867	0868	0869	0870	0871	0872	0873	0874	0875	0876	0877	0878	0879
37	0880	0881	0882	0883	0884	0885	0886	0887	0888	0889	0890	0891	0892	0893	0894	0895
38	0896	0897	0898	0899	0900	0901	0902	0903	0904	0905	0906	0907	0908	0909	0910	0911
39	0912	0913	0914	0915	0916	0917	0918	0919	0920	0921	0922	0923	0924	0925	0926	0927
3A	0928	0929	0930	0931	0932	0933	0934	0935	0936	0937	0938	0939	0940	0941	0942	0943
3B	0944	0945	0946	0947	0948	0949	0950	0951	0952	0953	0954	0955	0956	0957	0958	0959
3C	0960	0961	0962	0963	0964	0965	0966	0967	0968	0969	0970	0971	0972	0973	0974	0975
3D	0976	0977	0978	0979	0980	0981	0982	0983	0984	0985	0986	0987	0988	0989	0990	0991
3E	0992	0993	0994	0995	0996	0997	0998	0999	1000	1001	1002	1003	1004	1005	1006	1007
3F	1008	1009	1010	1011	1012	1013	1014	1015	1016	1017	1018	1019	1020	1021	1022	1023

APPENDIX J Cont'd.

	0	1	2	3	4	5	6	7	8	9	A	B	C	D	E	F
40	1024	1025	1026	1027	1028	1029	1030	1031	1032	1033	1034	1035	1036	1037	1038	1039
41	1040	1041	1042	1043	1044	1045	1046	1047	1048	1049	1050	1051	1052	1053	1054	1055
42	1056	1057	1058	1059	1060	1061	1062	1063	1064	1065	1066	1067	1068	1069	1070	1071
43	1072	1073	1074	1075	1076	1077	1078	1079	1080	1081	1082	1083	1084	1085	1086	1087
44	1088	1089	1090	1091	1092	1093	1094	1095	1096	1097	1098	1099	1100	1101	1102	1103
45	1104	1105	1106	1107	1108	1109	1110	1111	1112	1113	1114	1115	1116	1117	1118	1119
46	1120	1121	1122	1123	1124	1125	1126	1127	1128	1129	1130	1131	1132	1133	1134	1135
47	1136	1137	1138	1139	1140	1141	1142	1143	1144	1145	1146	1147	1148	1149	1150	1151
48	1152	1153	1154	1155	1156	1157	1158	1159	1160	1161	1162	1163	1164	1165	1166	1167
49	1168	1169	1170	1171	1172	1173	1174	1175	1176	1177	1178	1179	1180	1181	1182	1183
4A	1184	1185	1186	1187	1188	1189	1190	1191	1192	1193	1194	1195	1196	1197	1198	1199
4B	1200	1201	1202	1203	1204	1205	1206	1207	1208	1209	1210	1211	1212	1213	1214	1215
4C	1216	1217	1218	1219	1220	1221	1222	1223	1224	1225	1226	1227	1228	1229	1230	1231
4D	1232	1233	1234	1235	1236	1237	1238	1239	1240	1241	1242	1243	1244	1245	1246	1247
4E	1248	1249	1250	1251	1252	1253	1254	1255	1256	1257	1258	1259	1260	1261	1262	1263
4F	1264	1265	1266	1267	1268	1269	1270	1271	1272	1273	1274	1275	1276	1277	1278	1279

	0	1	2	3	4	5	6	7	8	9	A	B	C	D	E	F
50	1280	1281	1282	1283	1284	1285	1286	1287	1288	1289	1290	1291	1292	1293	1294	1295
51	1296	1297	1298	1299	1300	1301	1302	1303	1304	1305	1306	1307	1308	1309	1310	1311
52	1312	1313	1314	1315	1316	1317	1318	1319	1320	1321	1322	1323	1324	1325	1326	1327
53	1328	1329	1330	1331	1332	1333	1334	1335	1336	1337	1338	1339	1340	1341	1342	1343
54	1344	1345	1346	1347	1348	1349	1350	1351	1352	1353	1354	1355	1356	1357	1358	1359
55	1360	1361	1362	1363	1364	1365	1366	1367	1368	1369	1370	1371	1372	1373	1374	1375
56	1376	1377	1378	1379	1380	1381	1382	1383	1384	1385	1386	1387	1388	1389	1390	1391
57	1392	1393	1394	1395	1396	1397	1398	1399	1400	1401	1402	1403	1404	1405	1406	1407
58	1408	1409	1410	1411	1412	1413	1414	1415	1416	1417	1418	1419	1420	1421	1422	1423
59	1424	1425	1426	1427	1428	1429	1430	1431	1432	1433	1434	1435	1436	1437	1438	1439
5A	1440	1441	1442	1443	1444	1445	1446	1447	1448	1449	1450	1451	1452	1453	1454	1455
5B	1456	1457	1458	1459	1460	1461	1462	1463	1464	1465	1466	1467	1468	1469	1470	1471
5C	1472	1473	1474	1475	1476	1477	1478	1479	1480	1481	1482	1483	1484	1485	1486	1487
5D	1488	1489	1490	1491	1492	1493	1494	1495	1496	1497	1498	1499	1500	1501	1502	1503
5E	1504	1505	1506	1507	1508	1509	1510	1511	1512	1513	1514	1515	1516	1517	1518	1519
5F	1520	1521	1522	1523	1524	1525	1526	1527	1528	1529	1530	1531	1532	1533	1534	1535

	0	1	2	3	4	5	6	7	8	9	A	B	C	D	E	F
60	1536	1537	1538	1539	1540	1541	1542	1543	1544	1545	1546	1547	1548	1549	1550	1551
61	1552	1553	1554	1555	1556	1557	1558	1559	1560	1561	1562	1563	1564	1565	1566	1567
62	1568	1569	1570	1571	1572	1573	1574	1575	1576	1577	1578	1579	1580	1581	1582	1583
63	1584	1585	1586	1587	1588	1589	1590	1591	1592	1593	1594	1595	1596	1597	1598	1599
64	1600	1601	1602	1603	1604	1605	1606	1607	1608	1609	1610	1611	1612	1613	1614	1615
65	1616	1617	1618	1619	1620	1621	1622	1623	1624	1625	1626	1627	1628	1629	1630	1631
66	1632	1633	1634	1635	1636	1637	1638	1639	1640	1641	1642	1643	1644	1645	1646	1647
67	1648	1649	1650	1651	1652	1653	1654	1655	1656	1657	1658	1659	1660	1661	1662	1663
68	1664	1665	1666	1667	1668	1669	1670	1671	1672	1673	1674	1675	1676	1677	1678	1679
69	1680	1681	1682	1683	1684	1685	1686	1687	1688	1689	1690	1691	1692	1693	1694	1695
6A	1696	1697	1698	1699	1700	1701	1702	1703	1704	1705	1706	1707	1708	1709	1710	1711
6B	1712	1713	1714	1715	1716	1717	1718	1719	1720	1721	1722	1723	1724	1725	1726	1727
6C	1728	1729	1730	1731	1732	1733	1734	1735	1736	1737	1738	1739	1740	1741	1742	1743
6D	1744	1745	1746	1747	1748	1749	1750	1751	1752	1753	1754	1755	1756	1757	1758	1759
6E	1760	1761	1762	1763	1764	1765	1766	1767	1768	1769	1770	1771	1772	1773	1774	1775
6F	1776	1777	1778	1779	1780	1781	1782	1783	1784	1785	1786	1787	1788	1789	1790	1791

	0	1	2	3	4	5	6	7	8	9	A	B	C	D	E	F
70	1792	1793	1794	1795	1796	1797	1798	1799	1800	1801	1802	1803	1804	1805	1806	1807
71	1808	1809	1810	1811	1812	1813	1814	1815	1816	1817	1818	1819	1820	1821	1822	1823
72	1824	1825	1826	1827	1828	1829	1830	1831	1832	1833	1834	1835	1836	1837	1838	1839
73	1840	1841	1842	1843	1844	1845	1846	1847	1848	1849	1850	1851	1852	1853	1854	1855
74	1856	1857	1858	1859	1860	1861	1862	1863	1864	1865	1866	1867	1868	1869	1870	1871
75	1872	1873	1874	1875	1876	1877	1878	1879	1880	1881	1882	1883	1884	1885	1886	1887
76	1888	1889	1890	1891	1892	1893	1894	1895	1896	1897	1898	1899	1900	1901	1902	1903
77	1904	1905	1906	1907	1908	1909	1910	1911	1912	1913	1914	1915	1916	1917	1918	1919
78	1920	1921	1922	1923	1924	1925	1926	1927	1928	1929	1930	1931	1932	1933	1934	1935
79	1936	1937	1938	1939	1940	1941	1942	1943	1944	1945	1946	1947	1948	1949	1950	1951
7A	1952	1953	1954	1955	1956	1957	1958	1959	1960	1961	1962	1963	1964	1965	1966	1967
7B	1968	1969	1970	1971	1972	1973	1974	1975	1976	1977	1978	1979	1980	1981	1982	1983
7C	1984	1985	1986	1987	1988	1989	1990	1991	1992	1993	1994	1995	1996	1997	1998	1999
7D	2000	2001	2002	2003	2004	2005	2006	2007	2008	2009	2010	2011	2012	2013	2014	2015
7E	2016	2017	2018	2019	2020	2021	2022	2023	2024	2025	2026	2027	2028	2029	2030	2031
7F	2032	2033	2034	2035	2036	2037	2038	2039	2040	2041	2042	2043	2044	2045	2046	2047

APPENDIX J Cont'd.

	0	1	2	3	4	5	6	7	8	9	A	B	C	D	E	F
80	2048	2049	2050	2051	2052	2053	2054	2055	2056	2057	2058	2059	2060	2061	2062	2063
81	2064	2065	2066	2067	2068	2069	2070	2071	2072	2073	2074	2075	2076	2077	2078	2079
82	2080	2081	2082	2083	2084	2085	2086	2087	2088	2089	2090	2091	2092	2093	2094	2095
83	2096	2097	2098	2099	2100	2101	2102	2103	2104	2105	2106	2107	2108	2109	2110	2111
84	2112	2113	2114	2115	2116	2117	2118	2119	2120	2121	2122	2123	2124	2125	2126	2127
85	2128	2129	2130	2131	2132	2133	2134	2135	2136	2137	2138	2139	2140	2141	2142	2143
86	2144	2145	2146	2147	2148	2149	2150	2151	2152	2153	2154	2155	2156	2157	2158	2159
87	2160	2161	2162	2163	2164	2165	2166	2167	2168	2169	2170	2171	2172	2173	2174	2175
88	2176	2177	2178	2179	2180	2181	2182	2183	2184	2185	2186	2187	2188	2189	2190	2191
89	2192	2193	2194	2195	2196	2197	2198	2199	2200	2201	2202	2203	2204	2205	2206	2207
8A	2208	2209	2210	2211	2212	2213	2214	2215	2216	2217	2218	2219	2220	2221	2222	2223
8B	2224	2225	2226	2227	2228	2229	2230	2231	2232	2233	2234	2235	2236	2237	2238	2239
8C	2240	2241	2242	2243	2244	2245	2246	2247	2248	2249	2250	2251	2252	2253	2254	2255
8D	2256	2257	2258	2259	2260	2261	2262	2263	2264	2265	2266	2267	2268	2269	2270	2271
8E	2272	2273	2274	2275	2276	2277	2278	2279	2280	2281	2282	2283	2284	2285	2286	2287
8F	2288	2289	2290	2291	2292	2293	2294	2295	2296	2297	2298	2299	2300	2301	2302	2303

	0	1	2	3	4	5	6	7	8	9	A	B	C	D	E	F
90	2304	2305	2306	2307	2308	2309	2310	2311	2312	2313	2314	2315	2316	2317	2318	2319
91	2320	2321	2322	2323	2324	2325	2326	2327	2328	2329	2330	2331	2332	2333	2334	2335
92	2336	2337	2338	2339	2340	2341	2342	2343	2344	2345	2346	2347	2348	2349	2350	2351
93	2352	2353	2354	2355	2356	2357	2358	2359	2360	2361	2362	2363	2364	2365	2366	2367
94	2368	2369	2370	2371	2372	2373	2374	2375	2376	2377	2378	2379	2380	2381	2382	2383
95	2384	2385	2386	2387	2388	2389	2390	2391	2392	2393	2394	2395	2396	2397	2398	2399
96	2400	2401	2402	2403	2404	2405	2406	2407	2408	2409	2410	2411	2412	2413	2414	2415
97	2416	2417	2418	2419	2420	2421	2422	2423	2424	2425	2426	2427	2428	2429	2430	2431
98	2432	2433	2434	2435	2436	2437	2438	2439	2440	2441	2442	2443	2444	2445	2446	2447
99	2448	2449	2450	2451	2452	2453	2454	2455	2456	2457	2458	2459	2460	2461	2462	2463
9A	2464	2465	2466	2467	2468	2469	2470	2471	2472	2473	2474	2475	2476	2477	2478	2479
9B	2480	2481	2482	2483	2484	2485	2486	2487	2488	2489	2490	2491	2492	2493	2494	2495
9C	2496	2497	2498	2499	2500	2501	2502	2503	2504	2505	2506	2507	2508	2509	2510	2511
9D	2512	2513	2514	2515	2516	2517	2518	2519	2520	2521	2522	2523	2524	2525	2526	2527
9E	2528	2529	2530	2531	2532	2533	2534	2535	2536	2537	2538	2539	2540	2541	2542	2543
9F	2544	2545	2546	2547	2548	2549	2550	2551	2552	2553	2554	2555	2556	2557	2558	2559

	0	1	2	3	4	5	6	7	8	9	A	B	C	D	E	F
A0	2560	2561	2562	2563	2564	2565	2566	2567	2568	2569	2570	2571	2572	2573	2574	2575
A1	2576	2577	2578	2579	2580	2581	2582	2583	2584	2585	2586	2587	2588	2589	2590	2591
A2	2592	2593	2594	2595	2596	2597	2598	2599	2600	2601	2602	2603	2604	2605	2606	2607
A3	2608	2609	2610	2611	2612	2613	2614	2615	2616	2617	2618	2619	2620	2621	2622	2623
A4	2624	2625	2626	2627	2628	2629	2630	2631	2632	2633	2634	2635	2636	2637	2638	2639
A5	2640	2641	2642	2643	2644	2645	2646	2647	2648	2649	2650	2651	2652	2653	2654	2655
A6	2656	2657	2658	2659	2660	2661	2662	2663	2664	2665	2666	2667	2668	2669	2670	2671
A7	2672	2673	2674	2675	2676	2677	2678	2679	2680	2681	2682	2683	2684	2685	2686	2687
A8	2688	2689	2690	2691	2692	2693	2694	2695	2696	2697	2698	2699	2700	2701	2702	2703
A9	2704	2705	2706	2707	2708	2709	2710	2711	2712	2713	2714	2715	2716	2717	2718	2719
AA	2720	2721	2722	2723	2724	2725	2726	2727	2728	2729	2730	2731	2732	2733	2734	2735
AB	2736	2737	2738	2739	2740	2741	2742	2743	2744	2745	2746	2747	2748	2749	2750	2751
AC0	2752	2753	2754	2755	2756	2757	2758	2759	2760	2761	2762	2763	2764	2765	2766	2767
AD0	2768	2769	2770	2771	2772	2773	2774	2775	2776	2777	2778	2779	2780	2781	2782	2783
AE0	2784	2785	2786	2787	2788	2789	2790	2791	2792	2793	2794	2795	2796	2797	2798	2799
AFO	2800	2801	2802	2803	2804	2805	2806	2807	2808	2809	2810	2811	2812	2813	2814	2815

	0	1	2	3	4	5	6	7	8	9	A	B	C	D	E	F
B0	2816	2817	2818	2819	2820	2821	2822	2823	2824	2825	2826	2827	2828	2829	2830	2831
B1	2832	2833	2834	2835	2836	2837	2838	2839	2840	2841	2842	2843	2844	2845	2846	2847
B2	2848	2849	2850	2851	2852	2853	2854	2855	2856	2857	2858	2859	2860	2861	2862	2863
B3	2864	2865	2866	2867	2868	2869	2870	2871	2872	2873	2874	2875	2876	2877	2878	2879
B4	2880	2881	2882	2883	2884	2885	2886	2887	2888	2889	2890	2891	2892	2893	2894	2895
B5	2896	2897	2898	2899	2900	2901	2902	2903	2904	2905	2906	2907	2908	2909	2910	2911
B6	2912	2913	2914	2915	2916	2917	2918	2919	2920	2921	2922	2923	2924	2925	2926	2927
B7	2928	2929	2930	2931	2932	2933	2934	2935	2936	2937	2938	2939	2940	2941	2942	2943
B8	2944	2945	2946	2947	2948	2949	2950	2951	2952	2953	2954	2955	2956	2957	2958	2959
B9	2960	2961	2962	2963	2964	2965	2966	2967	2968	2969	2970	2971	2972	2973	2974	2975
BA	2976	2977	2978	2979	2980	2981	2982	2983	2984	2985	2986	2987	2988	2989	2990	2991
BB	2992	2993	2994	2995	2996	2997	2998	2999	3000	3001	3002	3003	3004	3005	3006	3007
BC	3008	3009	3010	3011	3012	3013	3014	3015	3016	3017	3018	3019	3020	3021	3022	3023
BD	3024	3025	3026	3027	3028	3029	3030	3031	3032	3033	3034	3035	3036	3037	3038	3039
BE	3040	3041	3042	3043	3044	3045	3046	3047	3048	3049	3050	3051	3052	3053	3054	3055
BF	3056	3057	3058	3059	3060	3061	3062	3063	3064	3065	3066	3067	3068	3069	3070	3071

APPENDIX J Cont'd.

	J	1	2	3	4	5	6	7	8	9	A	B	C	D	E	F
CO	3072	3073	3074	3075	3076	3077	3078	3079	3080	3081	3082	3083	3084	3085	3086	3087
CI	3088	3089	3090	3091	3092	3093	3094	3095	3096	3097	3098	3099	3100	3101	3102	3103
C2	3104	3105	3106	3107	3108	3109	3110	3111	3112	3113	3114	3115	3116	3117	3118	3119
C3	3120	3121	3122	3123	3124	3125	3126	3127	3128	3129	3130	3131	3132	3133	3134	3135
C4	3136	3137	3138	3139	3140	3141	3142	3143	3144	3145	3146	3147	3148	3149	3150	3151
C5	3152	3153	3154	3155	3156	3157	3158	3159	3160	3161	3162	3163	3164	3165	3166	3167
C6	3168	3169	3170	3171	3172	3173	3174	3175	3176	3177	3178	3179	3180	3181	3182	3183
C7	3184	3185	3186	3187	3188	3189	3190	3191	3192	3193	3194	3195	3196	3197	3198	3199
C8	3200	3201	3202	3203	3204	3205	3206	3207	3208	3209	3210	3211	3212	3213	3214	3215
C9	3216	3217	3218	3219	3220	3221	3222	3223	3224	3225	3226	3227	3228	3229	3230	3231
CA	3232	3233	3234	3235	3236	3237	3238	3239	3240	3241	3242	3243	3244	3245	3246	3247
CB	3248	3249	3250	3251	3252	3253	3254	3255	3256	3257	3258	3259	3260	3261	3262	3263
CC	3264	3265	3266	3267	3268	3269	3270	3271	3272	3273	3274	3275	3276	3277	3278	3279
CD	3280	3281	3282	3283	3284	3285	3286	3287	3288	3289	3290	3291	3292	3293	3294	3295
CE	3296	3297	3298	3299	3300	3301	3302	3303	3304	3305	3306	3307	3308	3309	3310	3311
CF	3312	3313	3314	3315	3316	3317	3318	3319	3320	3321	3322	3323	3324	3325	3326	3327

	J	1	2	3	4	5	6	7	8	9	A	B	C	D	E	F
DO	3328	3329	3330	3331	3332	3333	3334	3335	3336	3337	3338	3339	3340	3341	3342	3343
D1	3344	3345	3346	3347	3348	3349	3350	3351	3352	3353	3354	3355	3356	3357	3358	3359
D2	3360	3361	3362	3363	3364	3365	3366	3367	3368	3369	3370	3371	3372	3373	3374	3375
D3	3376	3377	3378	3379	3380	3381	3382	3383	3384	3385	3386	3387	3388	3389	3390	3391
D4	3392	3393	3394	3395	3396	3397	3398	3399	3400	3401	3402	3403	3404	3405	3406	3407
D5	3408	3409	3410	3411	3412	3413	3414	3415	3416	3417	3418	3419	3420	3421	3422	3423
D6	3424	3425	3426	3427	3428	3429	3430	3431	3432	3433	3434	3435	3436	3437	3438	3439
D7	3440	3441	3442	3443	3444	3445	3446	3447	3448	3449	3450	3451	3452	3453	3454	3455
D8	3456	3457	3458	3459	3460	3461	3462	3463	3464	3465	3466	3467	3468	3469	3470	3471
D9	3472	3473	3474	3475	3476	3477	3478	3479	3480	3481	3482	3483	3484	3485	3486	3487
DA	3488	3489	3490	3491	3492	3493	3494	3495	3496	3497	3498	3499	3500	3501	3502	3503
DB	3504	3505	3506	3507	3508	3509	3510	3511	3512	3513	3514	3515	3516	3517	3518	3519
DC	3520	3521	3522	3523	3524	3525	3526	3527	3528	3529	3530	3531	3532	3533	3534	3535
DD	3536	3537	3538	3539	3540	3541	3542	3543	3544	3545	3546	3547	3548	3549	3550	3551
DE	3552	3553	3554	3555	3556	3557	3558	3559	3560	3561	3562	3563	3564	3565	3566	3567
DF	3568	3569	3570	3571	3572	3573	3574	3575	3576	3577	3578	3579	3580	3581	3582	3583

	J	1	2	3	4	5	6	7	8	9	A	B	C	D	E	F
E0	3584	3585	3586	3587	3588	3589	3590	3591	3592	3593	3594	3595	3596	3597	3598	3599
E1	3600	3601	3602	3603	3604	3605	3606	3607	3608	3609	3610	3611	3612	3613	3614	3615
E2	3616	3617	3618	3619	3620	3621	3622	3623	3624	3625	3626	3627	3628	3629	3630	3631
E3	3632	3633	3634	3635	3636	3637	3638	3639	3640	3641	3642	3643	3644	3645	3646	3647
E4	3648	3649	3650	3651	3652	3653	3654	3655	3656	3657	3658	3659	3660	3661	3662	3663
E5	3664	3665	3666	3667	3668	3669	3670	3671	3672	3673	3674	3675	3676	3677	3678	3679
E6	3680	3681	3682	3683	3684	3685	3686	3687	3688	3689	3690	3691	3692	3693	3694	3695
E7	3696	3697	3698	3699	3700	3701	3702	3703	3704	3705	3706	3707	3708	3709	3710	3711
E8	3712	3713	3714	3715	3716	3717	3718	3719	3720	3721	3722	3723	3724	3725	3726	3727
E9	3728	3729	3730	3731	3732	3733	3734	3735	3736	3737	3738	3739	3740	3741	3742	3743
EA	3744	3745	3746	3747	3748	3749	3750	3751	3752	3753	3754	3755	3756	3757	3758	3759
EB	3760	3761	3762	3763	3764	3765	3766	3767	3768	3769	3770	3771	3772	3773	3774	3775
EC	3776	3777	3778	3779	3780	3781	3782	3783	3784	3785	3786	3787	3788	3789	3790	3791
ED	3792	3793	3794	3795	3796	3797	3798	3799	3800	3801	3802	3803	3804	3805	3806	3807
EE	3808	3809	3810	3811	3812	3813	3814	3815	3816	3817	3818	3819	3820	3821	3822	3823
EF	3824	3825	3826	3827	3828	3829	3830	3831	3832	3833	3834	3835	3836	3837	3838	3839

	J	1	2	3	4	5	6	7	8	9	A	B	C	D	E	F
FO	3840	3841	3842	3843	3844	3845	3846	3847	3848	3849	3850	3851	3852	3853	3854	3855
F1	3856	3857	3858	3859	3860	3861	3862	3863	3864	3865	3866	3867	3868	3869	3870	3871
F2	3872	3873	3874	3875	3876	3877	3878	3879	3880	3881	3882	3883	3884	3885	3886	3887
F3	3888	3889	3890	3891	3892	3893	3894	3895	3896	3897	3898	3899	3900	3901	3902	3903
F4	3904	3905	3906	3907	3908	3909	3910	3911	3912	3913	3914	3915	3916	3917	3918	3919
F5	3920	3921	3922	3923	3924	3925	3926	3927	3928	3929	3930	3931	3932	3933	3934	3935
F6	3936	3937	3938	3939	3940	3941	3942	3943	3944	3945	3946	3947	3948	3949	3950	3951
F7	3952	3953	3954	3955	3956	3957	3958	3959	3960	3961	3962	3963	3964	3965	3966	3967
F8	3968	3969	3970	3971	3972	3973	3974	3975	3976	3977	3978	3979	3980	3981	3982	3983
F9	3984	3985	3986	3987	3988	3989	3990	3991	3992	3993	3994	3995	3996	3997	3998	3999
FA	4000	4001	4002	4003	4004	4005	4006	4007	4008	4009	4010	4011	4012	4013	4014	4015
FB	4016	4017	4018	4019	4020	4021	4022	4023	4024	4025	4026	4027	4028	4029	4030	4031
FC	4032	4033	4034	4035	4036	4037	4038	4039	4040	4041	4042	4043	4044	4045	4046	4047
FD	4048	4049	4050	4051	4052	4053	4054	4055	4056	4057	4058	4059	4060	4061	4062	4063
FE	4064	4065	4066	4067	4068	4069	4070	4071	4072	4073	4074	4075	4076	4077	4078	4079
FF	4080	4081	4082	4083	4084	4085	4086	4087	4088	4089	4090	4091	4092	4093	4094	4095

APPENDIX K

COMMAND SUMMARY

COMMAND NAME	PARAMETERS	DESCRIPTION
DUMP.	LOC, FWA-LWA(; ... ;LOC, FWA-LWA)	Display the area of memory. FWA-LWA, whenever the instruction at LOC executes.
FEND	None	Execute the last simulation and terminate the entire run.
INPUT	VALUE(; ... ;VALUE)	Define the data to be read by simulated I/O instructions.
INSTR.	LOC(; ... ;LOC)	Display the processor registers whenever the instruction at LOC executes.
LIMIT	NO	Specify the total number of instructions executed.
PATCH	LOC,VALUE(; ... ;LOC,VALUE)	Initialize each memory location, LOC, to VALUE.
REFER.	LOC(; ... ;LOC)	Display the processor register whenever the instruction at LOC is referenced by another instruction.
SETP.	LOC,(PSL=VALUE) (,PSU=VALUE)	Set the program status byte (lower and/or upper) to VALUE whenever the instruction at LOC executes.
SETR.	LOC,(R0=VALUE)..(R6=VALUE)	Set the general purpose registers to VALUE whenever the instruction at LOC executes.
SROM	FWA-LWA	Specify the boundaries of Read-Only Memory.
START	LOC	Start the simulated program execution at LOC.
STAT	None	Display instruction statistics at end of program execution.
STOP.	LOC(; ... ;LOC)	Terminate the program execution when the instruction at LOC executes.
TEND	None	Execute the last simulation and prepare to read the User Commands for the next simulation.
TRACE.	FWA-LWA(; ... ;FWA-LWA)	Display the processor registers whenever an instruction executes, which lies within the area of memory, FWA-LWA.

APPENDIX L

ERROR MESSAGES

Whenever the Simulator detects an error in the User Commands, it prints one of the following error messages:

ERROR IN OBJECT MODULE CARD NUMBER

the 2650 object module is incorrectly formatted.

INPUT DATA TABLE OVERFLOW

an INPUT command attempted to expand the simulated data input buffer beyond its limit (200 bytes).

PARAMETER OUT OF RANGE

a User Command either contains an address which is outside the bounds of simulated memory or the command defines a datum which is larger than one byte (255_{10}).

SIM MEMORY EXCEEDED

a 2650 object module loads into an area which is outside of simulated memory.

SYNTAX ERROR IN COMMAND

the command parameters are either missing or in error.

TOO MANY COMMANDS

the maximum number of dynamic commands has been exceeded.

TOO MANY DUMP COMMANDS

the maximum number of DUMP commands has been exceeded.

TOO MANY SET REGISTER COMMANDS

the maximum number of SETR. commands has been exceeded.

TOO MANY SET PSB COMMANDS

the maximum number of SETP. commands has been exceeded.

UNRECOGNIZED COMMAND

a command has been read which is unknown to the Simulator.

UNEXPECTED END OF FILE

either the object module or the set of User Commands is missing, or one of their respective card decks is incorrectly formatted, or the FEND command is missing.

Whenever the Simulator detects an error while the simulated program is executing it prints one of the following error messages:

ADDRESS OUT OF RANGE

an instruction attempted to access a location which lies outside of simulated memory.

INSUFFICIENT INPUT DATA

a I/O instruction attempted to read another datum from the input data buffer (INPUT) after all the data from the buffer had been read. The simulated input register remains unchanged i.e., the instruction is essentially ignored, and program execution continues.

LC= ATTEMPT TO STORE INTO ROM

an instruction attempted to store data into the area designated as ROM (SRAM).

LC EXCEEDS MEMORY

the program attempted to execute a memory location which lies outside of simulated memory.

NO KNOWN OPCODE

the program attempted to execute a memory location which did not contain a valid instruction. Either the program was modified during execution or the program is attempting to execute data.

APPENDIX M

SIMULATOR RESTRICTIONS

SIMULATOR RESTRICTIONS

1. The simulated memory reserved by the Simulator for program storage is limited to 2048 bytes.* Thus, the Simulator will accept only programs or program segments which fit into this area. This implies that the 2650 paging facility (page size = 8192 bytes) cannot be simulated.
2. Some User Commands are limited in the amount of entries they may accept.

COMMAND	LIMIT
DUMP.	5 LOC's
SETR.	4 LOC's
SETP.	2 LOC's
INPUT	200 VALUE's
All "dynamic" commands	30 LOC's (for TRACE, count 1 for each set of FWA-LWA)

APPENDIX N

SIMULATOR RUN PREPARATION

In order to prepare a program for execution by the Simulator, the programmer:

1. Codes a program in 2650 Assembly Language.
2. Assembles the program until no assembly errors occur.
3. Obtains the object module and listing for the assembled program.
4. Generates command cards using addresses from the listing of the assembled program.
5. Submits the object module and the command cards in that order for a Simulator run.

Signetics

a subsidiary of U.S. Philips Corporation

Signetics Corporation
PO Box 9052
811 East Arques Avenue
Sunnyvale, California 94086
Telephone 408/738-7700